



TITAN®

SUPERIOR BOLTING SOLUTIONS®

AT1400R

AirTite Pneumatic Torque Wrenches

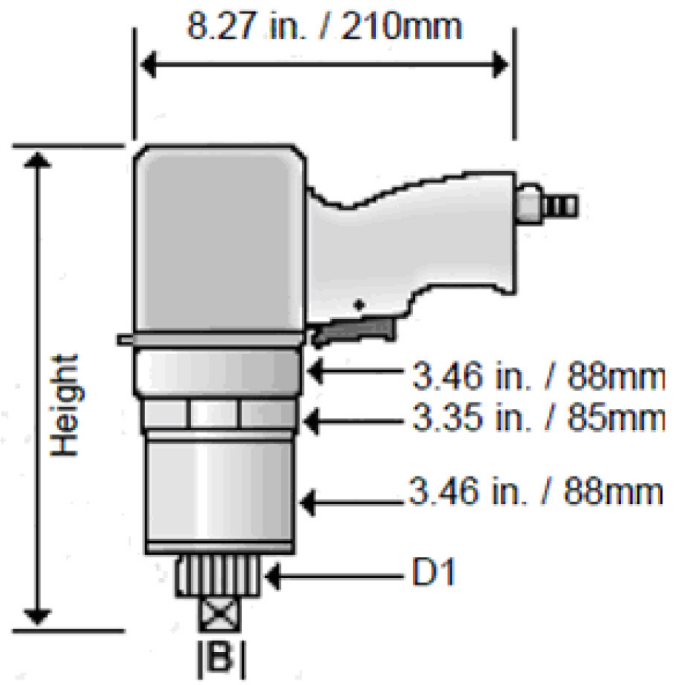

AT1400R AirTite R Series Single Speed:

Torque Range:	475 - 1400 ft lb 645 - 1900 nm	Precise and Accurate +/- 5%
Square Drive (B):	1 In	Filter/Regulator/Lubricator Assembly
D1:	2.13 In 54 mm	Pressure to Torque Chart
Height:	11.81 In 300 mm	360 Degree Articulating Motor
Free Speed (rpm):	7	15 ft. hose assy
Weight (without support):	16.1 In 7.3 kg	Operation/Maintenance Manual
1/2% Accurate Pressure Gauge:	QUIET - 66-78 dB(A)	Supplied with Calibration Certificate

(AirTite Series Accessories Professional Pictures)

Accessories

ARA 16 54 DW	Deep Reaction Arm
ARA 16 54 CN	Crab Nut Reaction Arm
ARA 16 54 ML	Mill Liner/Extended Reaction Arm
SRA 16 54	Straight Reaction Arm
PSR 16 54	Splined Reaction Ring
SDE 16 54 13	Sq. Dr. Extension 13"
SR 54	Safety Ring

SUPERIOR BOLTING SOLUTIONS®

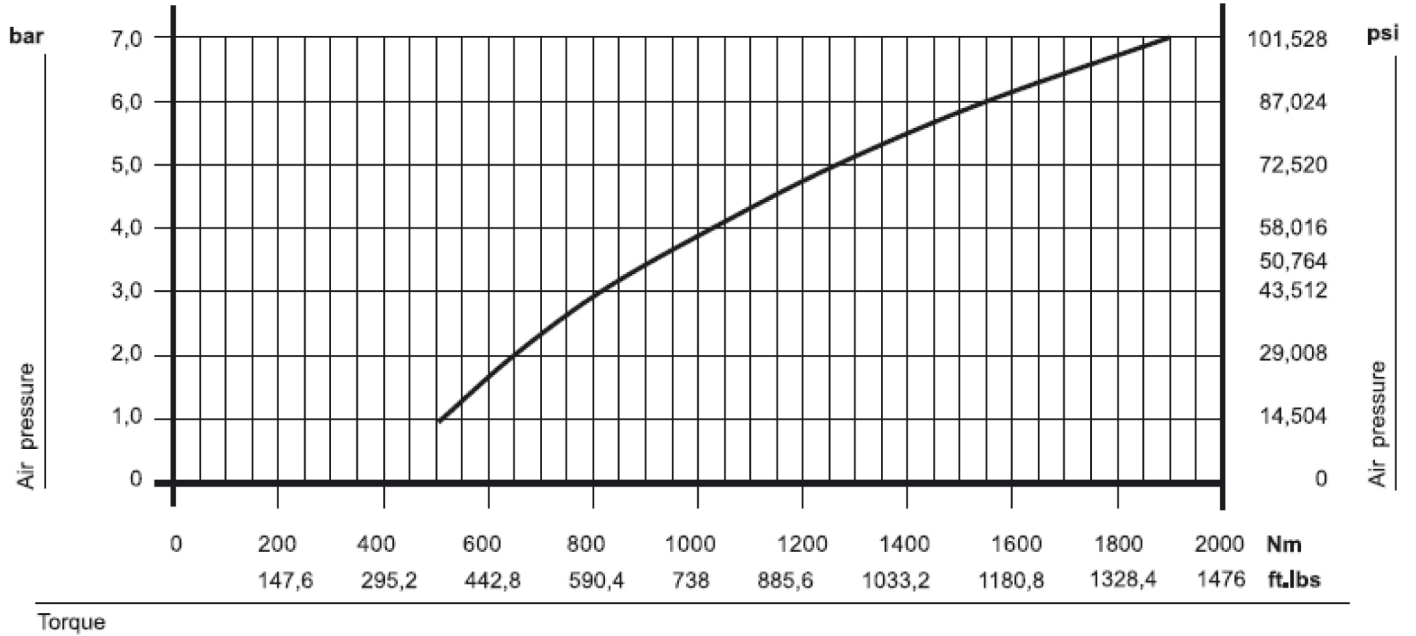

All curves are approximate values.
Unstable compressed air values can cause derivations.

Torque

Bar	NM	Ft Lbs
	Max	Max
2	645	476
3	815	603
4	1035	762
5	1265	934
6	1550	1144
7	1900	1401

Operating pressure on the machine
Air consumption: 21 – 32 cfm.

