



TITAN®

SUPERIOR BOLTING SOLUTIONS®

AT360R

AirTite Pneumatic Torque Wrenches

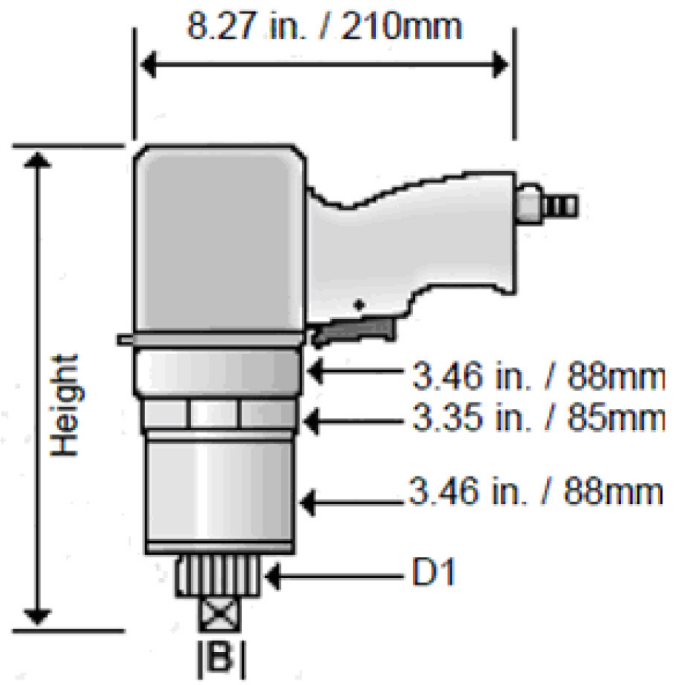

AT360R AirTite R Series Single Speed:

Torque Range:	120 - 360 ft lb 165 - 485 nm	Precise and Accurate +/- 5%
Square Drive (B):	3/4 In	Filter/Regulator/Lubricator Assembly
D1:	1.61 In 41 mm	Pressure to Torque Chart
Height:	10.04 In 255 mm	360 Degree Articulating Motor
Free Speed (rpm):	27	15 ft. hose assy
Weight (without support):	13.89 In 6.3 kg	Operation/Maintenance Manual
1/2% Accurate Pressure Gauge:	QUIET - 66-78 dB(A)	Supplied with Calibration Certificate

(AirTite Series Accessories Professional Pictures)

Accessories

ARA 12 41 DW	Deep Reaction Arm
ARA 12 41 CN	Crab Nut Reaction Arm
ARA 24 72 ML	Mill Liner/Extended Reaction Arm
ARA 12 41 ML	Straight Reaction Arm
SRA 12 41	Splined Reaction Ring
SDE 12 41 13	Sq. Dr. Extension 13"
SR 41	Safety Ring

SUPERIOR BOLTING SOLUTIONS®

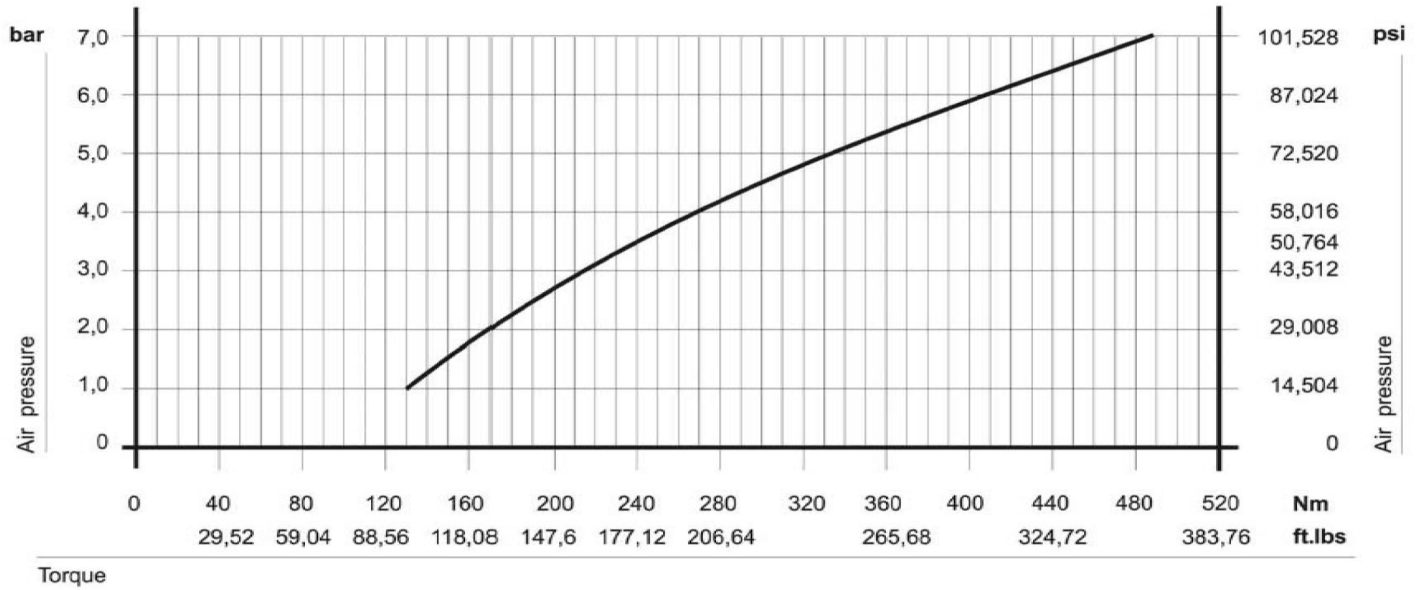

All curves are approximate values.
Unstable compressed air values can cause derivations.

Torque

Bar	NM Max	Ft Lbs Max
2	165	122
3	210	155
4	265	195
5	325	239
6	395	293
7	485	359

Operating pressure on the machine
Air consumption: 21 – 32 cfm.

