



TITAN®

SUPERIOR BOLTING SOLUTIONS®

AT660R

AirTite Pneumatic Torque Wrenches

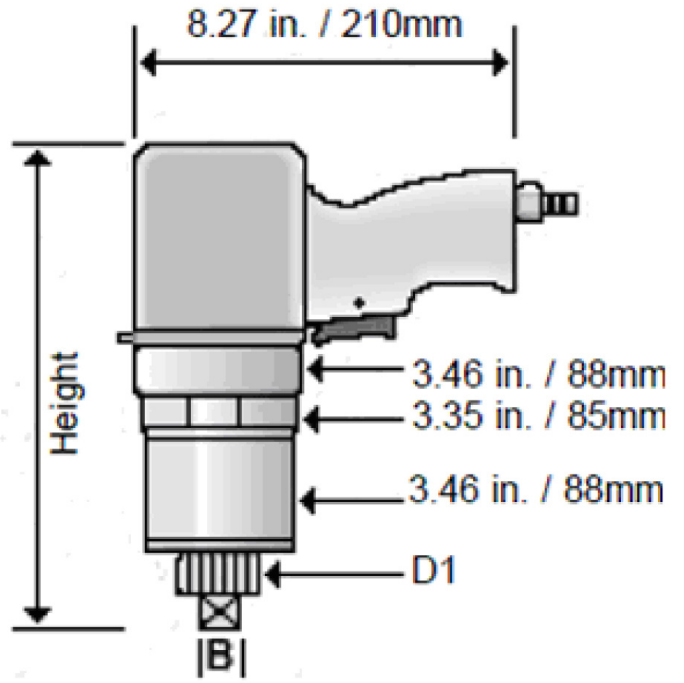

AT660R AirTite R Series Single Speed:

Torque Range:	225 - 660 ft lb 305 - 895 nm	Precise and Accurate +/- 5%
Square Drive (B):	3/4 In	Filter/Regulator/Lubricator Assembly
D1:	1.61 In 41 mm	Pressure to Torque Chart
Height:	10.83 In 275 mm	360 Degree Articulating Motor
Free Speed (rpm):	19	15 ft. hose assy
Weight (without support):	15.43 In 7 kg	Operation/Maintenance Manual
1/2% Accurate Pressure Gauge:	QUIET - 66-78 dB(A)	Supplied with Calibration Certificate

(AirTite Series Accessories Professional Pictures)

Accessories

ARA 12 41 DW	Deep Reaction Arm
ARA 12 41 CN	Crab Nut Reaction Arm
ARA 12 41 ML	Mill Liner/Extended Reaction Arm
ARA 12 41 ML	Straight Reaction Arm
SRA 12 41	Splined Reaction Ring
SDE 12 41 13	Sq. Dr. Extension 13"
SR 41	Safety Ring

SUPERIOR BOLTING SOLUTIONS®

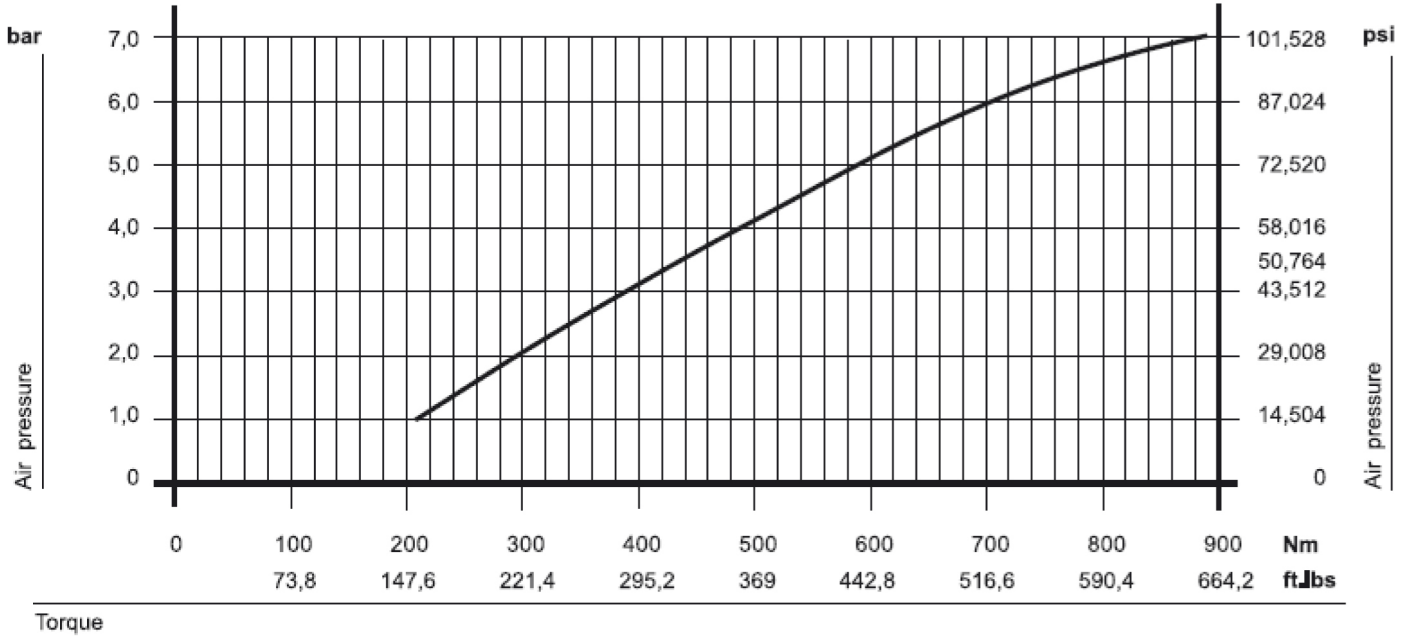

All curves are approximate values.
Unstable compressed air values can cause derivations.

Torque

Bar	NM	Ft Lbs
	Max	Max
2	305	224
3	385	284
4	485	359
5	595	439
6	730	538
7	895	659

Operating pressure on the machine
Air consumption: 21 – 32 cfm.

