

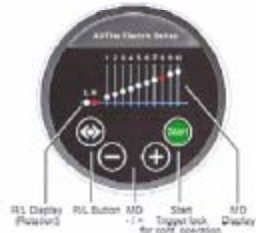

**TITAN**  
TECHNOLOGIES INTERNATIONAL, INC.  
SUPERIOR BOLTING SOLUTIONS

**Titan ETite Electric  
ETC, ETCip**

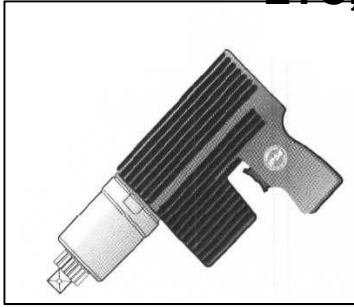

**Titan ETite Electric  
EIP-SG**

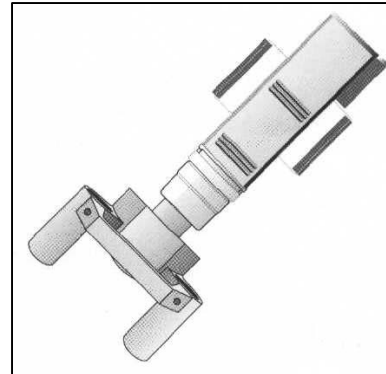

**Titan ETite Electric  
ETCip Plus**

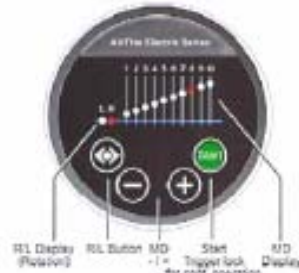
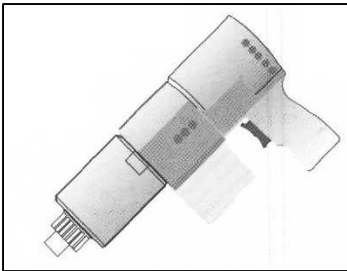

**Titan ETite™ Electric  
EHRA**

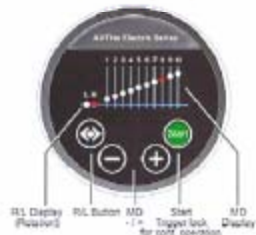
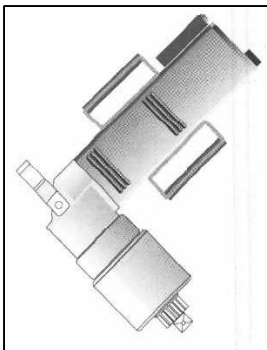

**Titan ETite™ Electric  
EIP**

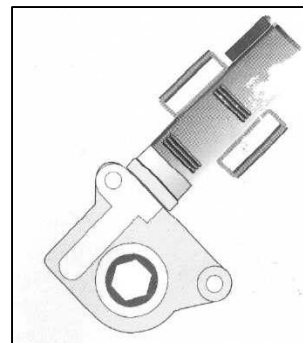

**Titan ETite Electric  
EHRA plus**





Read this and understand this manual before operate your ETite® Electronic Torque Wrench. The Safety Points (page 24) must strictly be adhered to.

ETite™ Electronic Torque Wrench **EIP**...degree of protection **IP 54**



ETite™ Electronic Torque Wrench – EIP / ETC ip...plus – Compact shut off Torque Tool Series for torques from approx. 70 Nm to 6,300 Nm.

High profitability due to problem-free operation in almost any kind of weather – dampness or rain. The construction of the tool is rated for Protection Art **IP 54!**

Suitable for all **international electric networks** and **electric generators** (100-253V / 45-66Hz).

#### **Integrated motor protection:**

ETite™ **Electric** – ETC ip, ETC ip plus with automatic safety monitoring. Permanent operation at the upper limit of the tool is prevented by means of a **temperature controlled safety function.** Thus the motor is constantly protected against damage caused by a possible overload.



#### **ATTENTION**

All safety Points both mechanical and electrical refer to the precise type, i.e. **ETC** or **ETC plus**

<b>Contents</b>	<b>Page</b>
A	Initial Control/Packaging 3
B	General Description 3
<b>1</b>	<b>Safety Hints</b> 5
1.1	Operators Responsibilities 5
1.2	Due Application 5
<b>2</b>	<b>Service</b> 5
2.1	Placing Tool in Service 6
<b>3</b>	<b>Electrical Operation</b> 8
3.1	<b>EFC / EFCip / EFC/L</b> 8
3.2	<b>EF / EFW / EFR / EF-SG</b> 10
3.3	<b>EFplus / EFWplus</b> 11
3.3.1	Primary Operation Unit 11
3.4	<b>EFCplus, EFCip plus</b> 11
3.5	Secondary Operation Unit: <b>EFplus, EFWplus, EFCplus, EFCip plus</b> 12
3.5.1	Torquing Programs - Standard 12
3.5.2	Adjustment of Programs: <b>EFplus, EFWplus, EFCplus, EFCip plus</b> 13
3.5.3	LC-Display 17
<b>4</b>	<b>Mechanical Operation</b> 18
4.1	Tightening and Loosening: <b>EF, EFW, EFC, EFC/L, EFCip and plus versions</b> 18
4.2	Tightening and Loosening: <b>EFR / EF-SG</b> 19
4.3	Finishing / Interrupting Operation 20
<b>5</b>	<b>Noise and Vibrations</b> 21
<b>6</b>	<b>Working Test</b> 21
6.1	Visual and Mechanical Check 21
6.2	Meeting the Deadline 21
<b>7</b>	<b>Maintenance / Servicing</b> 21
7.1	Replacement of Accessories 21
7.2	Maintenance Periods 22
7.3	Operational Hints 22
<b>8</b>	<b>Technical Hints</b>
	Safety shut off upon high Temperature of Motor 22
<b>9</b>	<b>Putting the Tool out of</b> 22
<b>10</b>	<b>Appendix</b> 22
	Replacing the Power Supply Plug 23
	Explanations, Warning Symbols, Notes 24

## A Initial Control and Packaging

### IMPORTANT!



Visually inspect all components for shipping damage. If any damage is found, notify the carrier immediately. All returns must be in original packaging in order to avoid damage to the **ETite® Electronic Torque Wrench**. Retain packaging.

## B General Description of the ETite™ Electronic Torque Wrenches

Operation via an electric and frequency controlled brush-free synchronized motor. High mounting speed. Reduction of shut-off speed when reaching required torque. Exact shut off and large torque range. Suitable for all international electric networks.

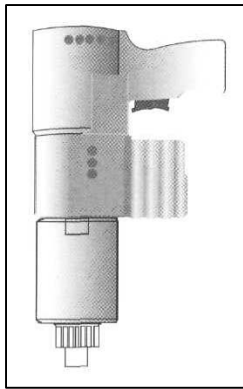

Type **ETC / ETC/L**



Type **ETC plus**

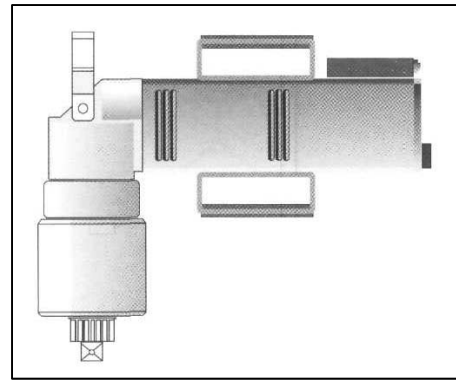

Type **EFW**



### ETite™ - ETC Compact Torque Wrench

Torques up to approx. 5,000 Nm (Type **ETC/L**: 2,300 Nm), CW/CCW-direction. Excellent for tap or torque tasks. Precise torque is obtainable within a wide torque range of 19 preset settings. Type **ETC plus** is computer controlled, providing the operator with a wider variety of torque settings and programs. Display: LC-Display.

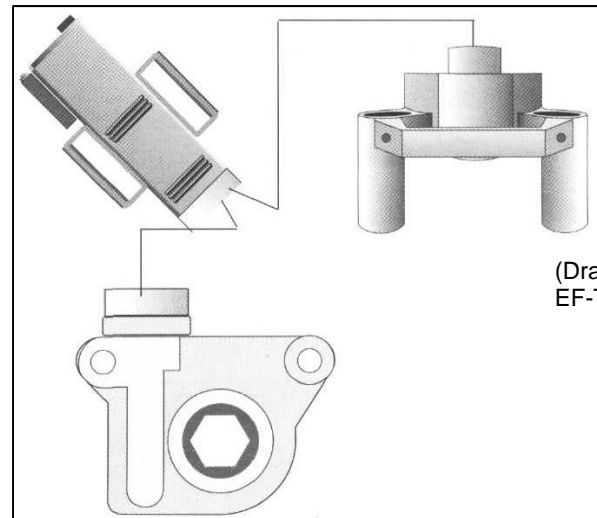

(Drawings of gearing EF-Torque Wrench)

### Titan ETite- EFR Radial Torque Wrench and EF-SG, Torque Wrenches with lateral gearing

...for applications with protruding studs such as plate heat exchangers

**EFR**: Torques up to approx. 3.600 Nm (higher torque ranges upon request)

**EF-SG (80)**: Torques up to approx. 4.000 Nm CW/CCW-direction and tap operation.

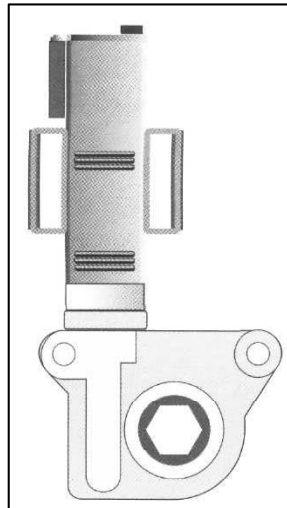
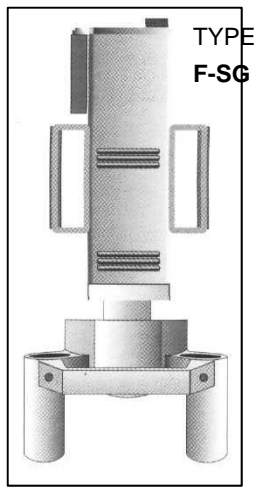

Original accessories for your special bolting application  
**Titan ETite™ DMA (1), Titan ETite™ STACO (2),**  
**Titan ETite™ STABI (3)**

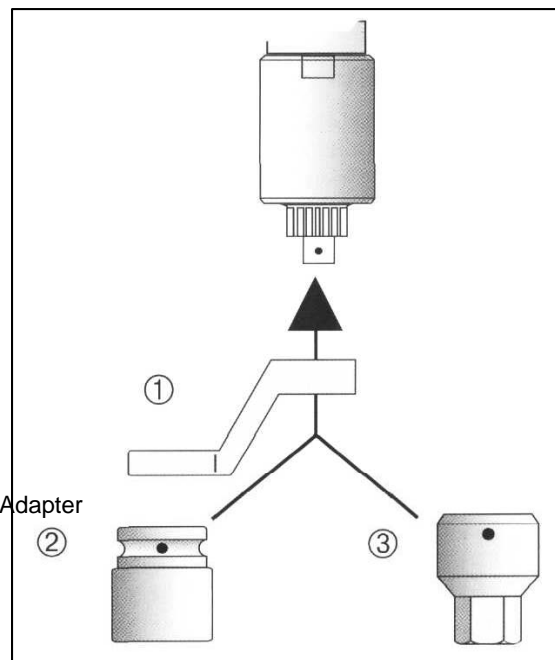
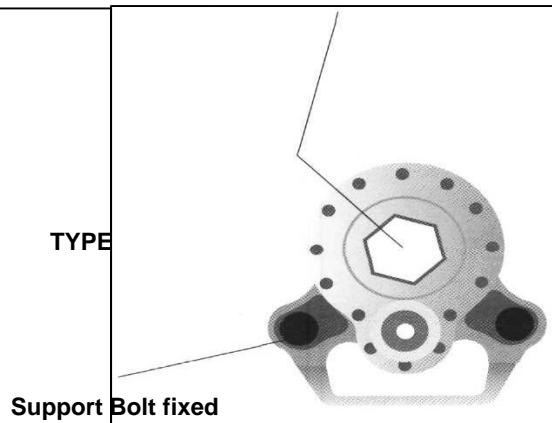
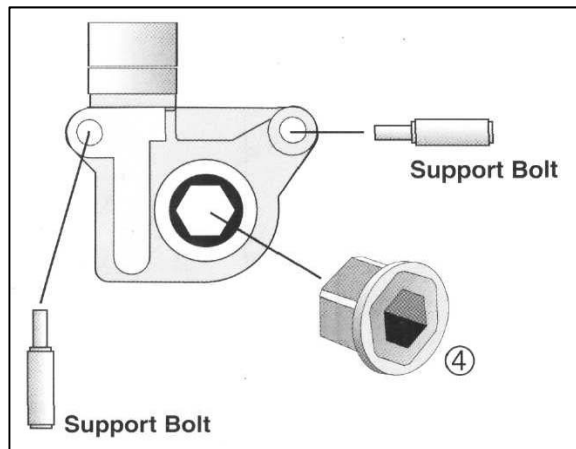
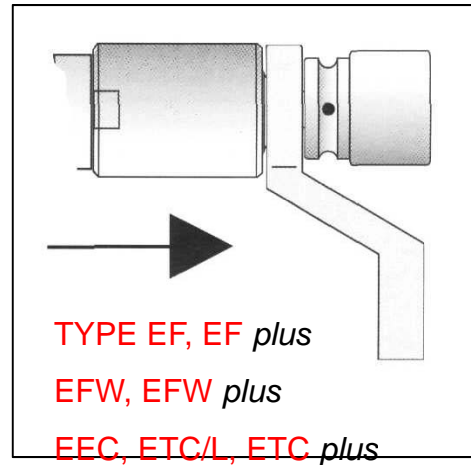

**Titan ETite™ -STACO**    **Titan ETite™ -STABI**  
 Standard Nut                      Standard Connector

## Titan ETite™ EF-Torque Wrench

Types: EF, *EF plus*, EFW, EFW p/tvs, ETC, ETC/L, *ETC plus*, EFR, EF-SG

### 1. Safety Points

#### 1.1 Operators Responsibilities

The **Titan ETite™ Torque Wrench** must not be operated or serviced unless the operator has read and fully understands the operations manual. The equipment must not be operated or serviced unless the operator fully understands the purpose, consequences and procedures necessary for each step.

#### 1.2 Due Application

**Titan ETite™ -Torque Wrenches** are designed for continuously tightening and loosening of heavy duty bolted connections. It is not suited for operations with mixing or drilling machines. This can damage the tool and/or injure the operator. External mechanical forces –such as using the tool as a crowbar- must not be exerted on the equipment (risk of deformation). For other applications not mentioned herein please consult Titan

### 2. Service

#### IMPORTANT



The **Titan ETite™ -Torque Wrenches** are rated for a voltage from 100 to 253 Volt with a frequency from 45 to 66 Hz. Nominal sensitivity is max. 2 kW.

#### WARNING!



Please observe local laws and regulations when using the tool - the **Titan ETite™ -EF-Torque Wrench is not for use in explosive environments** or in the presence of combustible materials (gas, varnish, fertilizer, gas stations etc.)

Compare motor nameplate against power availability to prevent motor burnout or dangerous electrical overloading. Make sure that the plugs and cords are secure before operating. When using the tool outdoors be sure to use the properly gauged exterior power cord. The **Titan ETite™ -EF-Torque Wrench** must not be used in wet areas. Depending on the working area and how the tool is used, local health and safety regulations may require that you to wear protective gear (e.g. ear protection, safety shoes, protective glasses, protective helmet etc.). In case external forces are exerted on the equipment non-compliance with these regulations may result in major injuries (e.g. electric shocks, bruises, head injuries due to moving parts).

#### IMPORTANT!



Should the **Titan ETite™ EF-Torque Wrenches** need to be used in rain or/and in damp areas, you must use our **Titan ETite™ -EF-Torque Wrench** with Protection Class "**IP 54**" to prevent injury or death due to electrocution.

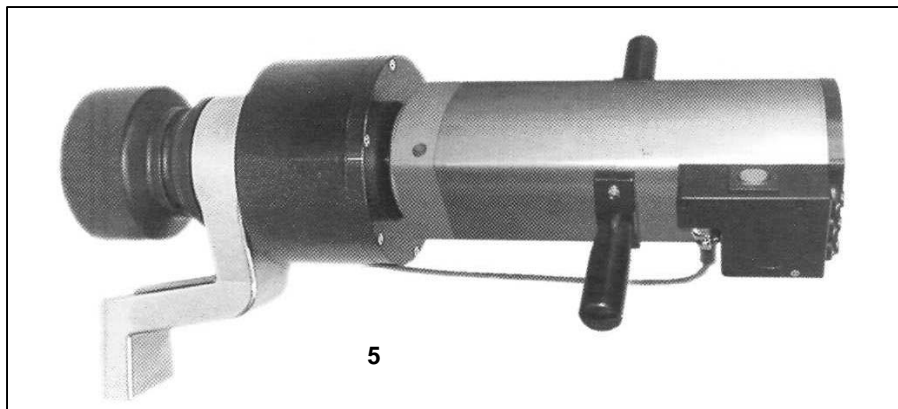

## 2.1 Placing Tool in Service

**Titan ETite™ -EF, ETC, ETCIL, EFW, EF plus, EFW plus and ETC plus.**

### WARNING!



Beware of high hydraulic pressure components and other hazards.  
Prepare your **Titan ETite™ -Torque Wrench** for your specific bolting application, **before you connect the plug! Double check** that the standard IMPACT sockets or any adapter are **correctly fitted** and undamaged.  
Never use damaged parts under any circumstances. Use original **Titan ETite™** - spare parts and accessories.  
Replacement of the power supply plug due to local & different power supplies must be performed according to the **Technical Order "Power/Power Supply Plug"** (see Appendix).

### IMPORTANT!



To tighten or loosen hard/soft joints, specific torque take ups or adapters may be needed in accordance with a specific bolting application (available as accessories, see Appendix). Standard nuts/-adapters are Placed on the square drive and secured. Replacement also see Chapter Service, Paragraph 6.1.

- Preparation for the bolting task:**
- Place the **Titan ETite™ - Torque Wrench** on a flat surface
  - Insert support arm/reaction arm onto spline (8)  
Secure with optional Rubber Safety Ring or with a special DMA (Safety screw is integrated), see Dwg. DMA-Examples with **Titan ETite™ -ETC**
  - Place standard nut/-connector on square drive (7)

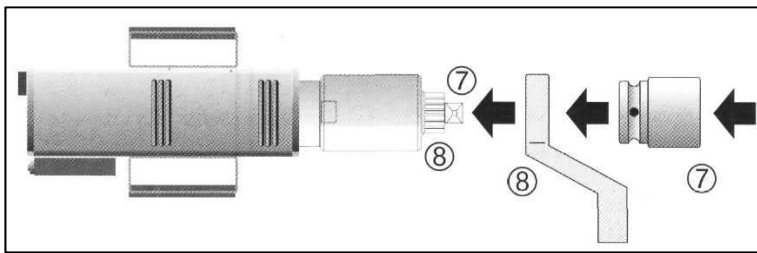

**Titan ETite™ ®-STACO**  
Standard Nut

**Titan ETite™ ®-DMA**  
Reaction Arm

### Preparation for the bolting task (2):

- Place rubber safety ring over pin, see Drawing below

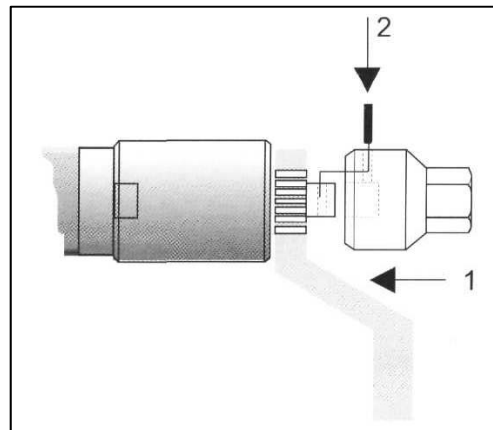
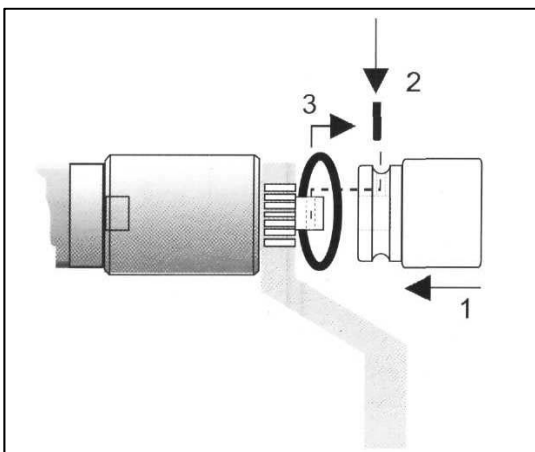

DMA-Examples

Rubber Safety Ring  
(DMAR optional)

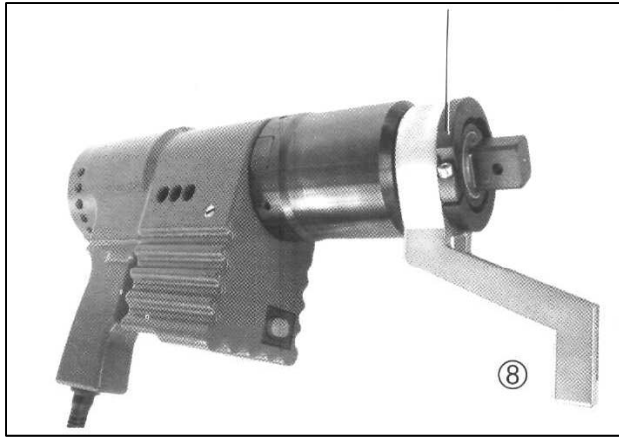

Safety Screw  
(integrated in the DMA)

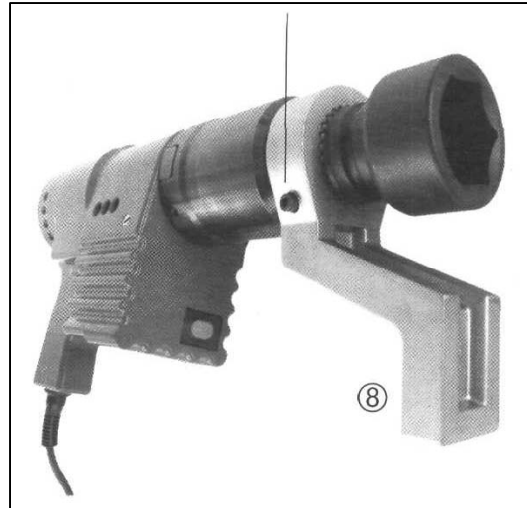

Preparation for the bolting task (3)

Two principles of construction within one tool:

A – freely rotating unit is independent of position of torque pick-up DMA is in use with the standard configuration

B - fixed joint between motor-/service unit and power gear - mechanically reversible (rigid connection) is available for special applications such as a right angle configuration

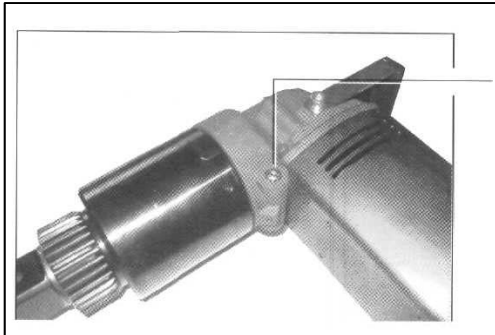

screw in blocking pin----->  
remove blocking pin.....>  
Example: Titan **ETite™** -EFW

power gear is fixed (rigid)  
power gear rotates freely

Blocking Pin stops  
Rotation between  
the motor and  
the gear box  
to makes a rigid  
connection

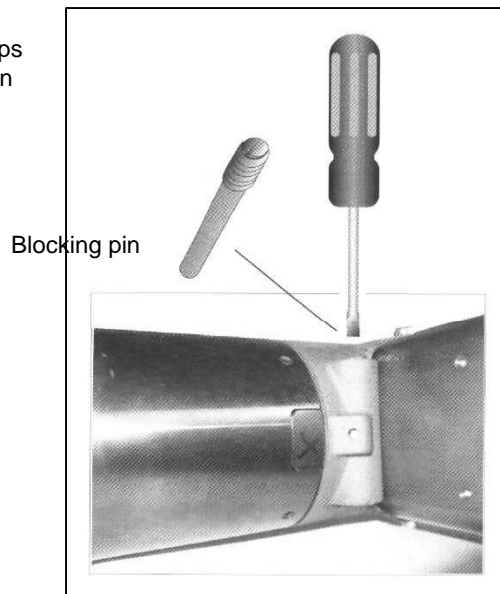

## Adjustment of Operation Unit "swiveling or rigid"

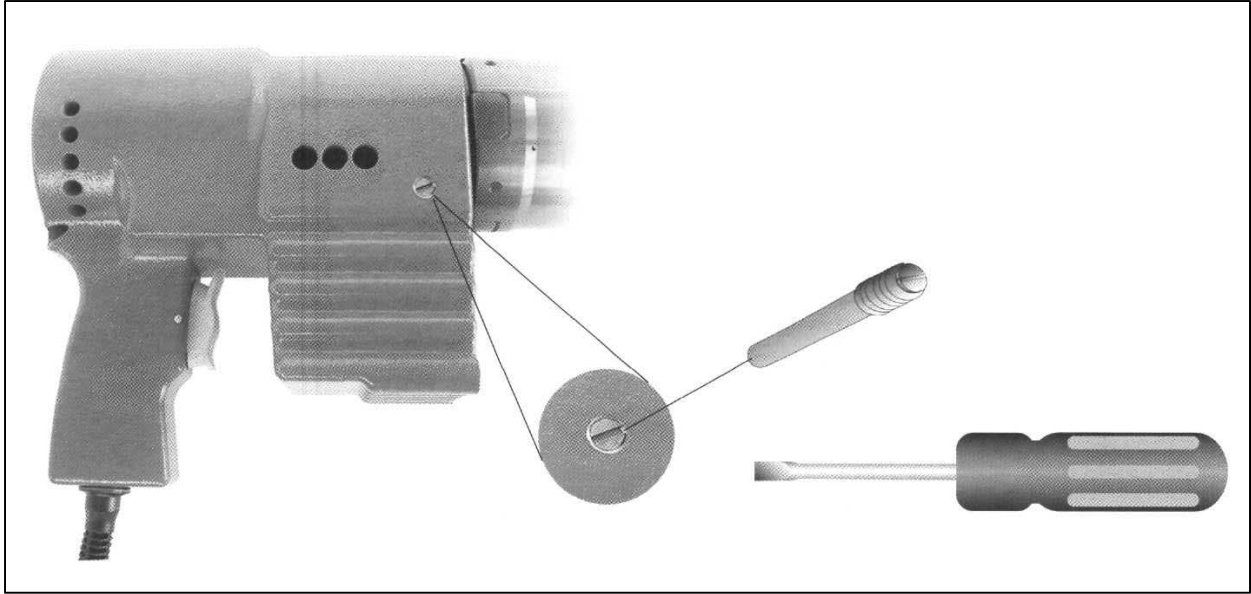

Two principles of construction within one tool:

A – freely rotating tool service unit is achievable by removing the locking screw. This makes the tool independent of position of torque pick-up DMA.

B – A fixed connection between motor-/service unit and power gear is achievable by the insertion and tightening of the locking screw -(rigid connection).

### 3. Electrical Operation

#### 3.1 Electrical Operation of the *Titan ETite™ -ETC I ETCIL*

##### Primary Operation Unit

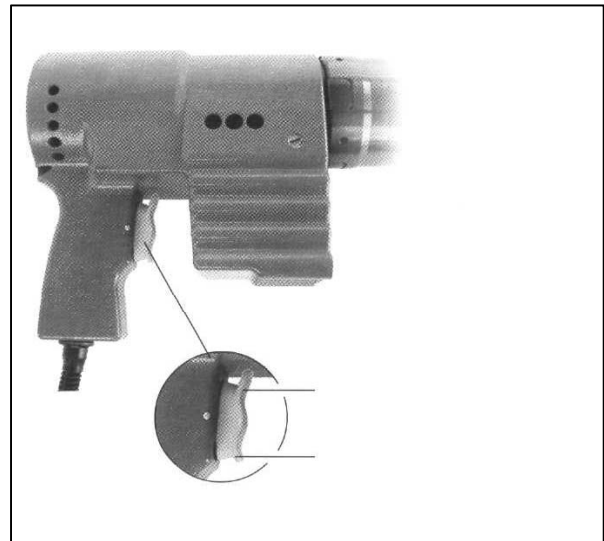
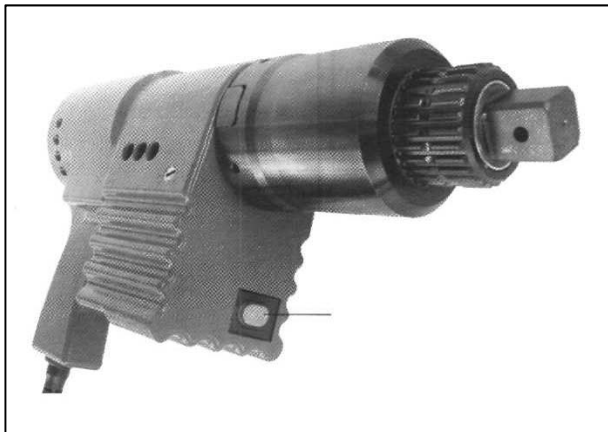

## Primary Operation Unit

Light-emitting button (1) - On/Off Switch of tool indicates Connection/Separation with/from power supply

Operation of tool with four-edge operation button (2)

Action point below: **CW-direction** - tap operation

In case the rocker button is pressed down continuously the torque wrench changes over to standard operation (when releasing the rocker button the tool stops)

Action point above: **CCW-direction** - tap operation

In case the rocker button is pressed down continuously the torque wrench changes over to standard operation (when releasing the rocker button the tool stops)

**Tool shuts off precisely when reaching the required torque.**

### **ATTENTION!**



**Before starting trigger lock for continuous operation.**

The electronic of the tool stores rotation which has been carried out last. e.g. key for CW-direction is activated - sense of rotation is automatically pre-set to right direction when starting trigger lock for continuous operation etc.. Corresponding LED (3) is flashing in Secondary Operation Unit (B) and displays sense of rotation. If you wish to change sense of rotation press key CW/CCW pre-set (4) or briefly press corresponding key (tap for CW/CCW-operation). Then start trigger lock for continuous operation.

Information: Pressing any button during trigger lock for continuous operation - bolting process stops

**Secondary**  
with LED

Torque presetting (-)

Torque presetting (+)

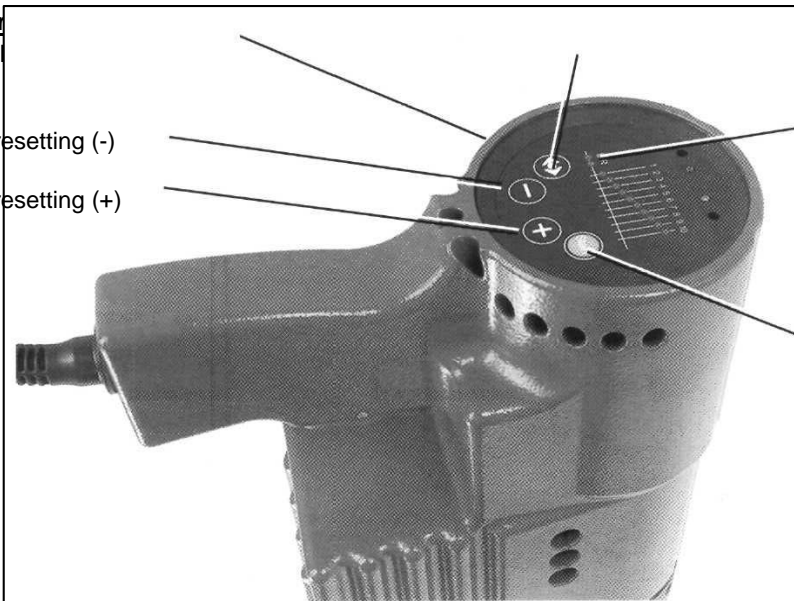

Left/right presetting (4)

Display sense of rotation (3)

Continuous operation Start (5)

### **Secondary Operation Unit (B)**

1. Presetting of desired torque limit-value via keys (+ / -)  
Steps 1-10 (one LED is flashing) and 9 intermediate stages (two LEDs are flashing) are selected.  
The figures 1-10 correspond with the Nm values according to the torque chart. Intermediate values are to be taken from the flow chart.
2. Display of sense of rotation (3) and CCW-/CW presetting (Change Over Button 4)
3. Trigger lock for continuous operation starts via the "Start" Button (5).

### 3.2 Electric Operation of the Titan ETite™ -EF | EFW | EFR | EF-SC

#### Primary Operation Unit (A)

Generally comprises:

1. Switching On/Off of tool, i.e. Connection/Separation with/from power supply (1)
2. Operation of tool during Mounting/Dismounting
  - Tap for CW operation (tool stops when releasing the button)
  - Tap for CCW operation (tool stops when releasing the button)
  - Start/Stop (when pressing the button the tool changes to trigger lock for continuous operation, pressing the button anew the tool stops - continuous operation is being stopped)

When reaching pre-set torque tool shuts off precisely.

#### **ATTENTION!** Before starting trigger lock for continuous operation.



The electronic of the tool stores rotation which has been carried out last. e.g. key for CW-direction is activated - sense of rotation is automatically pre-set to right direction when starting trigger lock for continuous operation etc.. Corresponding LED (3) is flashing in Secondary Operation Unit (B) and displays sense of rotation. If you wish to change sense of rotation press key CW/CCW pre-set (4) or briefly press corresponding key (tap for CW/CCW-operation). Then start trigger lock for continuous operation.

Information: Pressing any button during trigger lock for continuous operation - bolting process stops

#### Secondary Operation Unit (B) with LED Display

Display sense of rotation (3)  
CCW/CW preset (4)

Torque pre-setting (-)

Tool power supply  
On/Off (1)

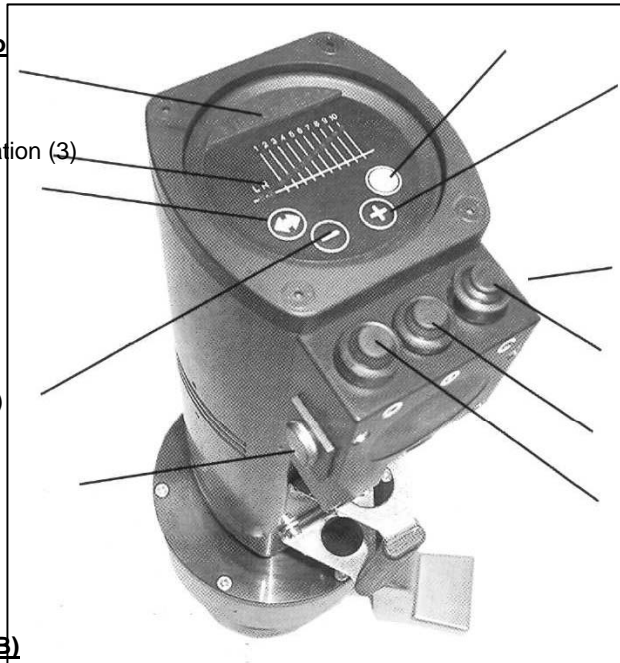

bolting process Start (5)

Torque pre-setting (+)

#### Primary Operation Unit (A)

Tap for CW operation

Trigger lock for continuous  
operation

Start/Stop -  
Tap for CCW operation

#### Secondary Operation Unit (B)

1. **Presetting of desired torque limit-value** via keys (+ / -)  
Steps 1-10 (one LED is flashing) and 9 intermediate stages (two LEDs are flashing) are selected. The figures 1-10 correspond with the Nm values according to the torque chart. Intermediate values are to be taken from the flow chart.
2. Display of sense of rotation (3) and CCW-/CW presetting (Change Over Button 4)
3. Trigger lock for continuous operation starts via the "Start" Button (5)\*\*



**\*\*NOTE!**  
We recommend to use the Start Button of the Primary Operation Unit (A) when Mounting- or Dismounting.

### 3.3. Electric Operation of the *Titan ETite™ -EF plus* and *EFW plus*

#### 3.3.1 Primary Operation Unit

Generally comprises:

1. Switching On/Off of tool, i.e. connection/separation with/from power supply (1)
2. Operation of tool while mounting/dismounting:
  - Tap for CW-operation (tool stops when releasing the button)
  - Tool Start (pressing the button tool changes to trigger lock for continuous operation according to pre-set mode - **Previously check sense of rotation in Secondary Operation Unit!**). When reaching pre-set torque or finishing-angle torque, tool shuts off precisely.
3. bolting process is being stopped by pressing any button during trigger lock for continuous operation.

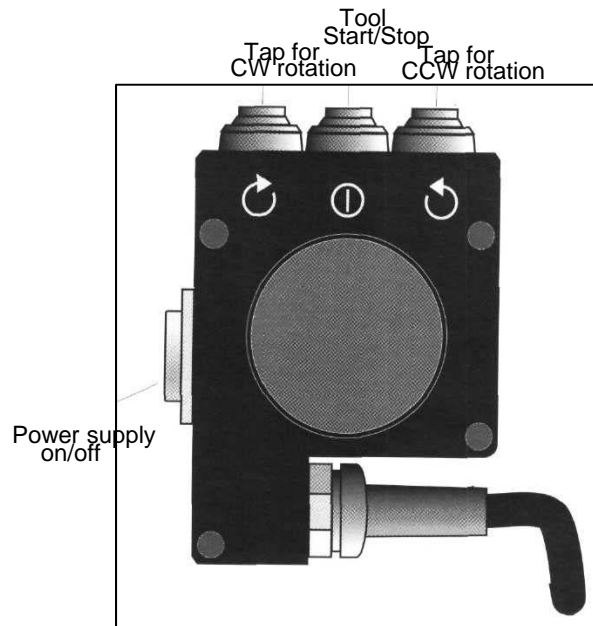

#### 3.4 Electrical Operation of the *Titan ETite™ -ETC plus*

##### Primary Operation Unit

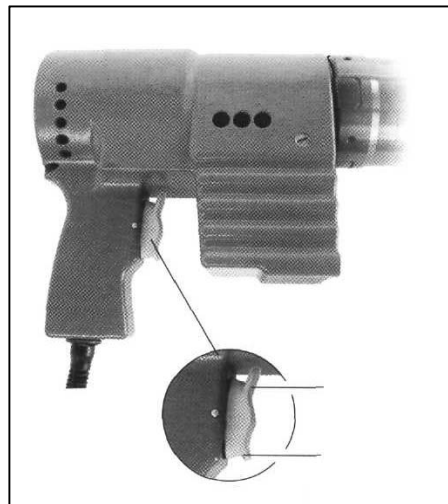
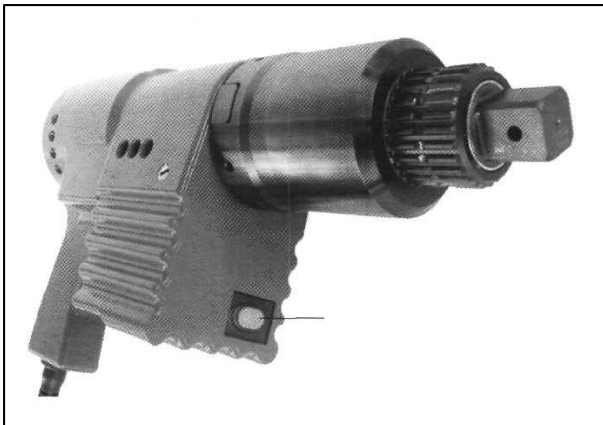

##### **Four-edge operation button (2)**

Tap operation left and quick CCW-rotation

Tap operation right and quick CW-rotation

##### Primary Operation Unit

Light-emitting button (1) - Switching On/Off of tool, which means Connection/Separation with/from power supply

**Operation** of tool with **four-edge operation button (2)**

Action point below: **CW-direction** - tap operation

In case the rocker button is pressed down continuously the torque wrench changes over to standard operation (when releasing the rocker button the tool stops)

Action point above: **CCW-direction** - tap operation

In case the rocker button is pressed down continuously the torque wrench changes over to standard operation (when releasing the rocker button the tool stops)

**Tool shuts off precisely when reaching the required torque.**

### 3.5 Secondary Operation Unit of the *Titan ETite™ -EF plus / EFW plus Iplus*

For adjustment of operation data response. programs



#### 3.5.1 bolting - Programs - Standard

Mode	Description
M 1	Tightening with torque Option: automatic loosening according to pre-settable angle degrees*
M 2	Tightening with pre-torque and finishing-angle rotation Option: automatic loosening according to pre-settable angle degrees*

#### Mode Important operational steps

M 1	Enter sense of rotation, nominal torque, Enter released angle
M 2	Enter sense of rotation, pre-torque and finishing-angle rotation Enter released angle

\* Attention: Releasing only serves to "free" the DMA (Torque Sensor) Its not for loosening the screw or nut

#### Optional Programs

Mode	Description
M 3	Tightening with angle degrees
M 4	Tightening with rotations

#### Mode Important operational steps

M 3	Enter sense of rotation and angle degrees
M 4	Enter sense of rotation and rotations

Selection of mode by pressing:

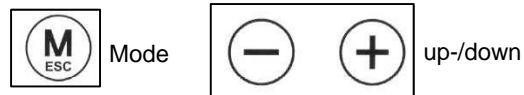

Cancellation of last input by pressing:

Escape - Function

Important:

Each operational step has to be confirmed by pressing:



Values or functional symbols are flashing continuously until confirmation is carried out

3.5.2 Adjustment of Programs *Titan ETite™ -EF plus, EFW plus, ETC plus*

Adjustment Mode 1

**Tightening with torque.** With/without automatic release

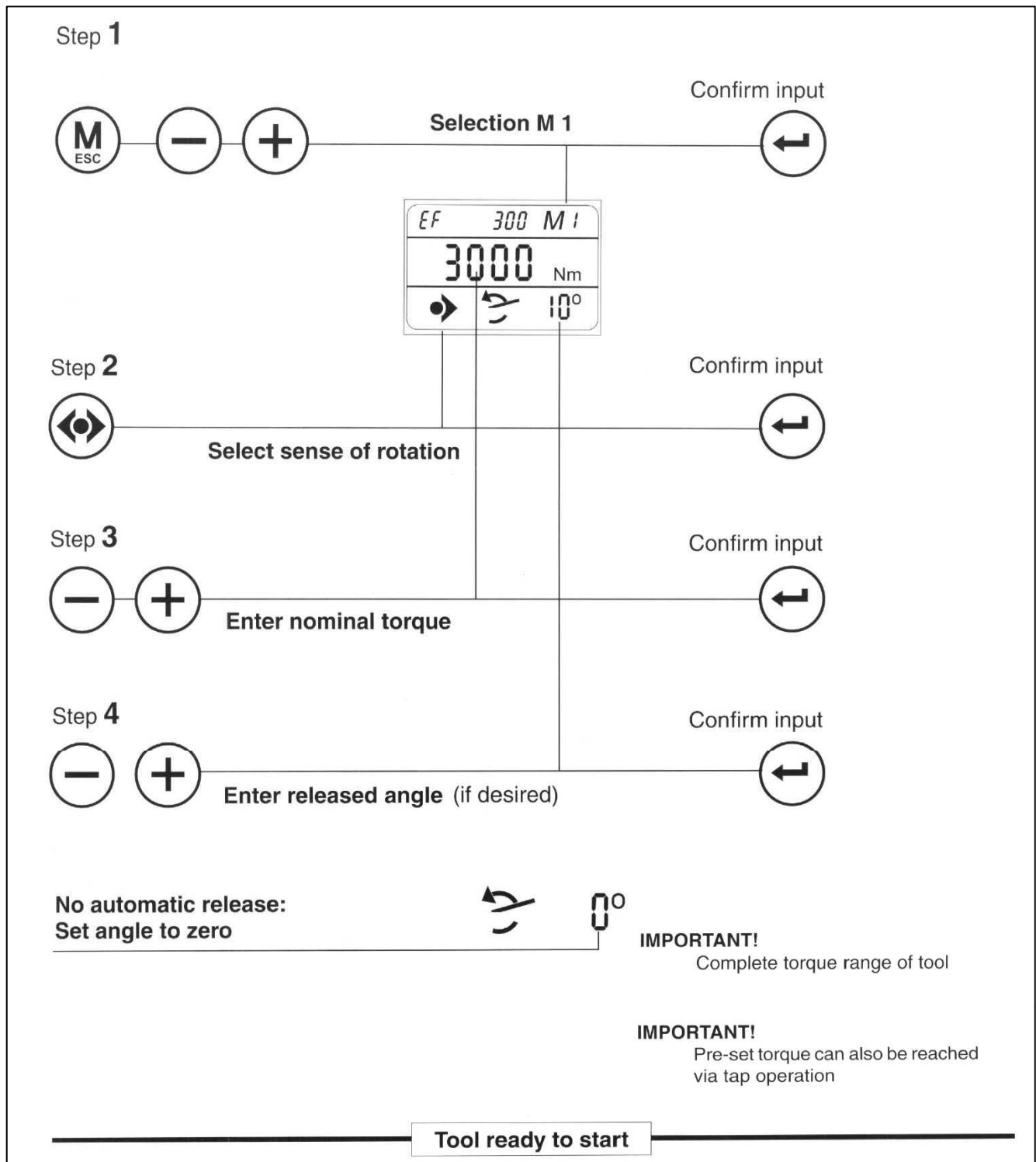

**Tightening with pre-set torque and finishing-angle torque. With/without automatic release**

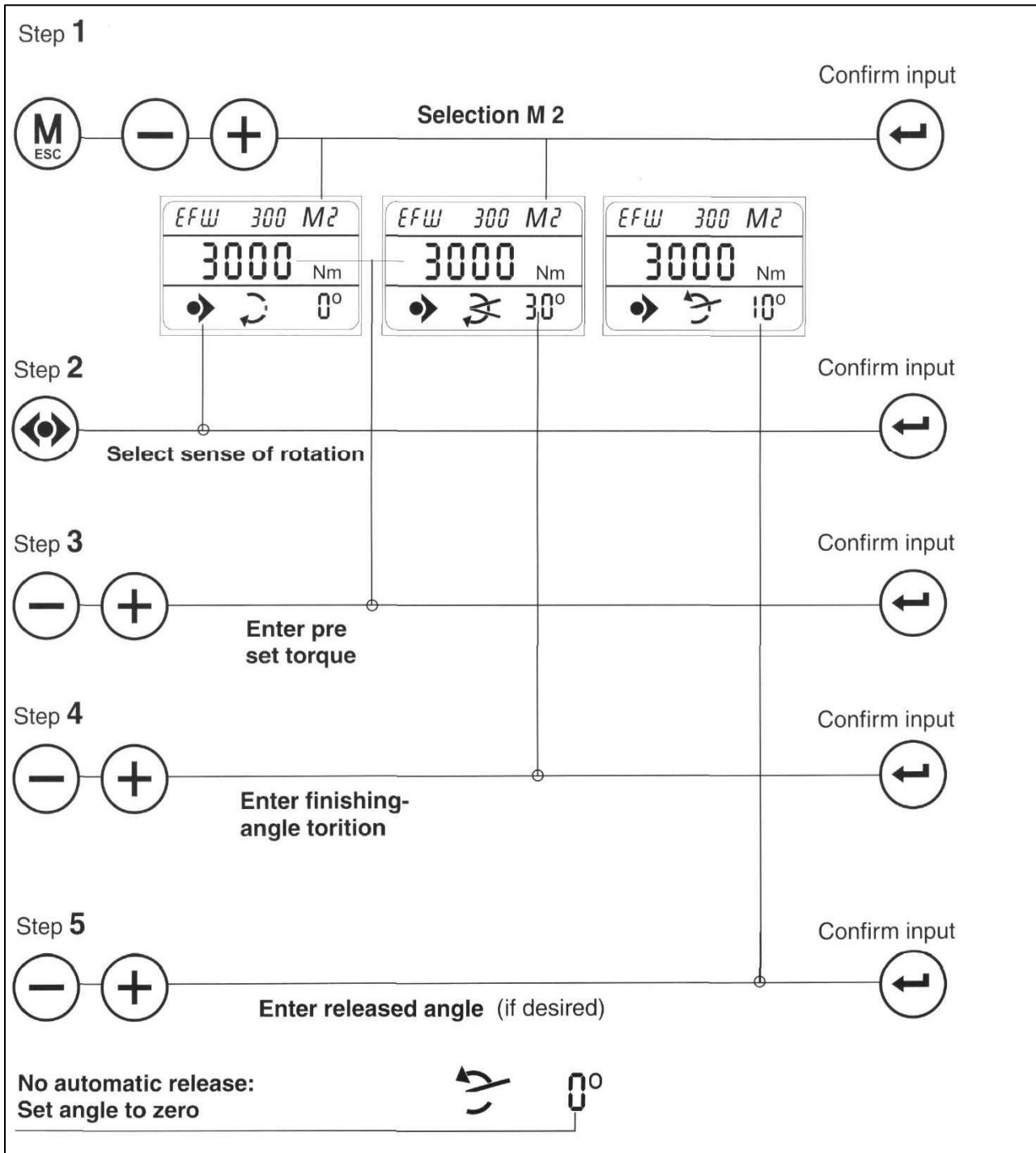

**IMPORTANT!**

When entering pre torque the

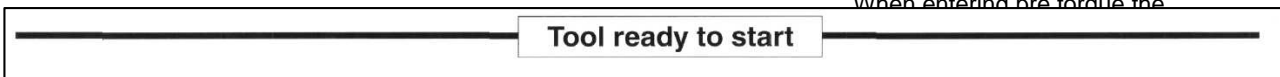

finishing-angle rotation

**Optional**

Adjustment Mode 3

Tightening with pre-set angle degrees.

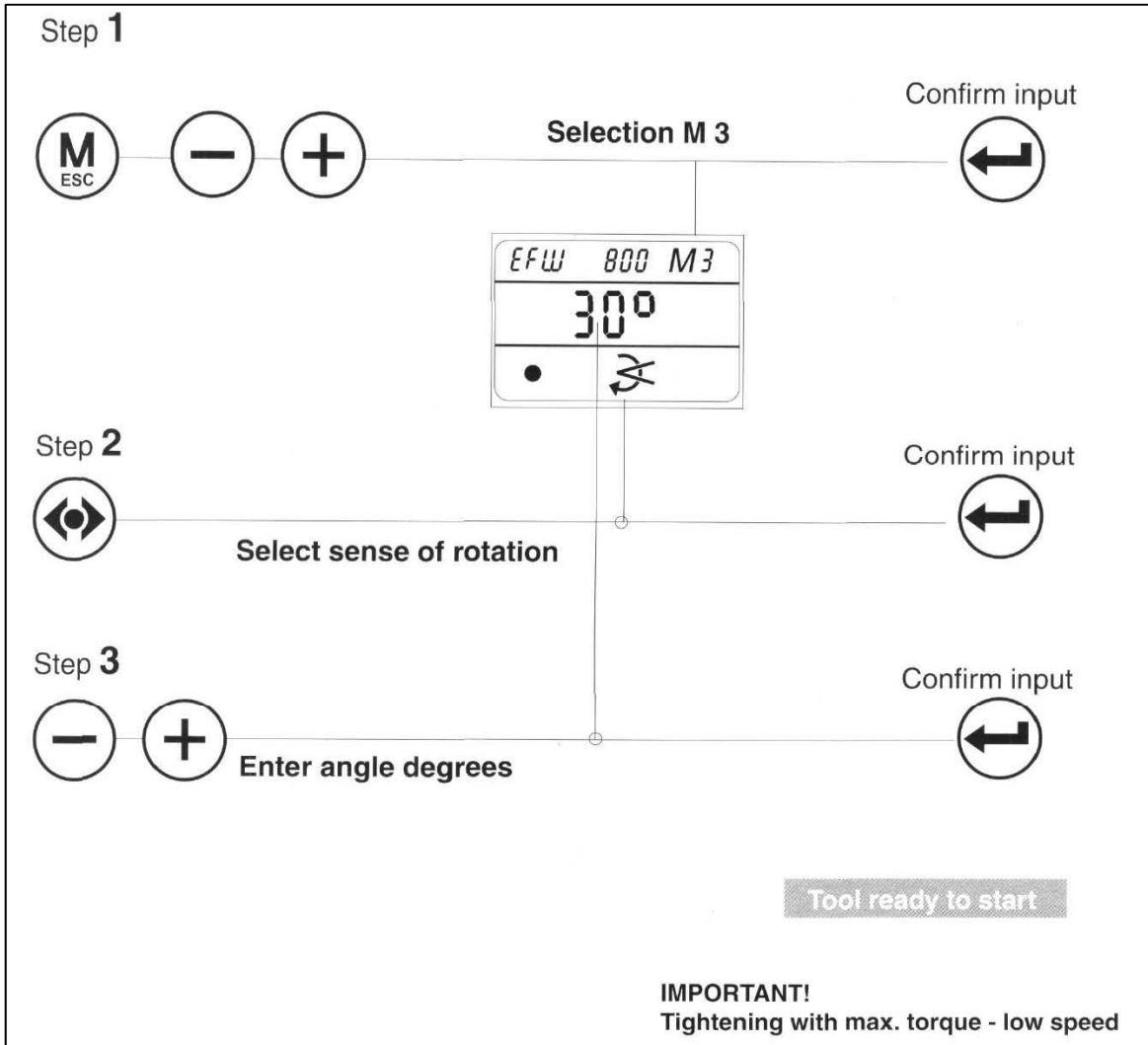

**Optional**

Adjustment Mode 4

Tightening with pre-set rotations

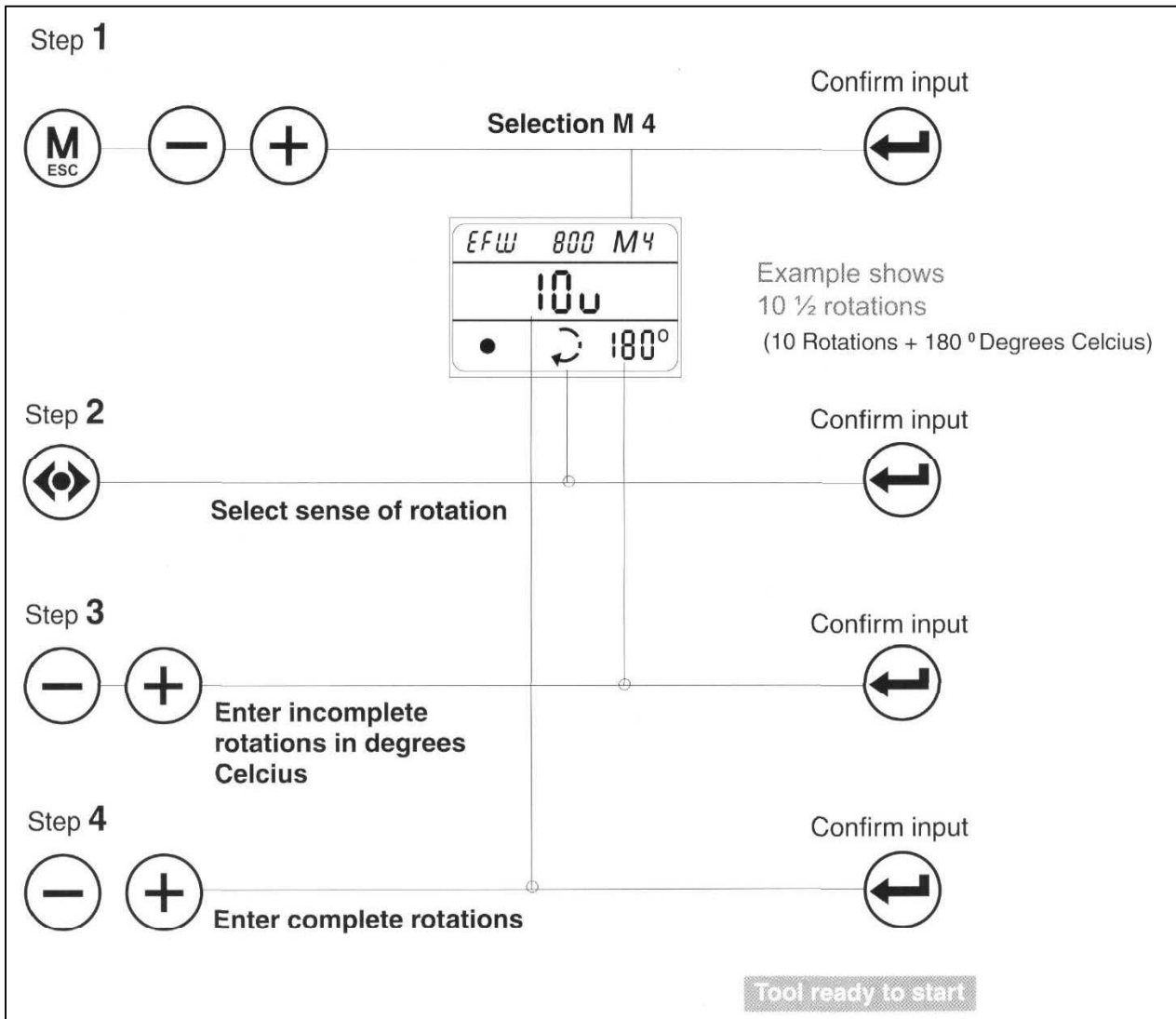

**IMPORTANT!**

Tool operates with max. torque, manual regulation is not provided.  
An internal electronic motor protection is standard.

**Recommendation!**

With the remote control FBE you may read the display up to a distance of 5 m.

**IMPORTANT for operation as a Spindle Torque range!**

Display of rotations during operation:

Generally rotations are counted counter "0", which means always the remaining rotations are being displayed.  
When operation is interrupted remaining rotations are also displayed.



3.5.3 LC-Display

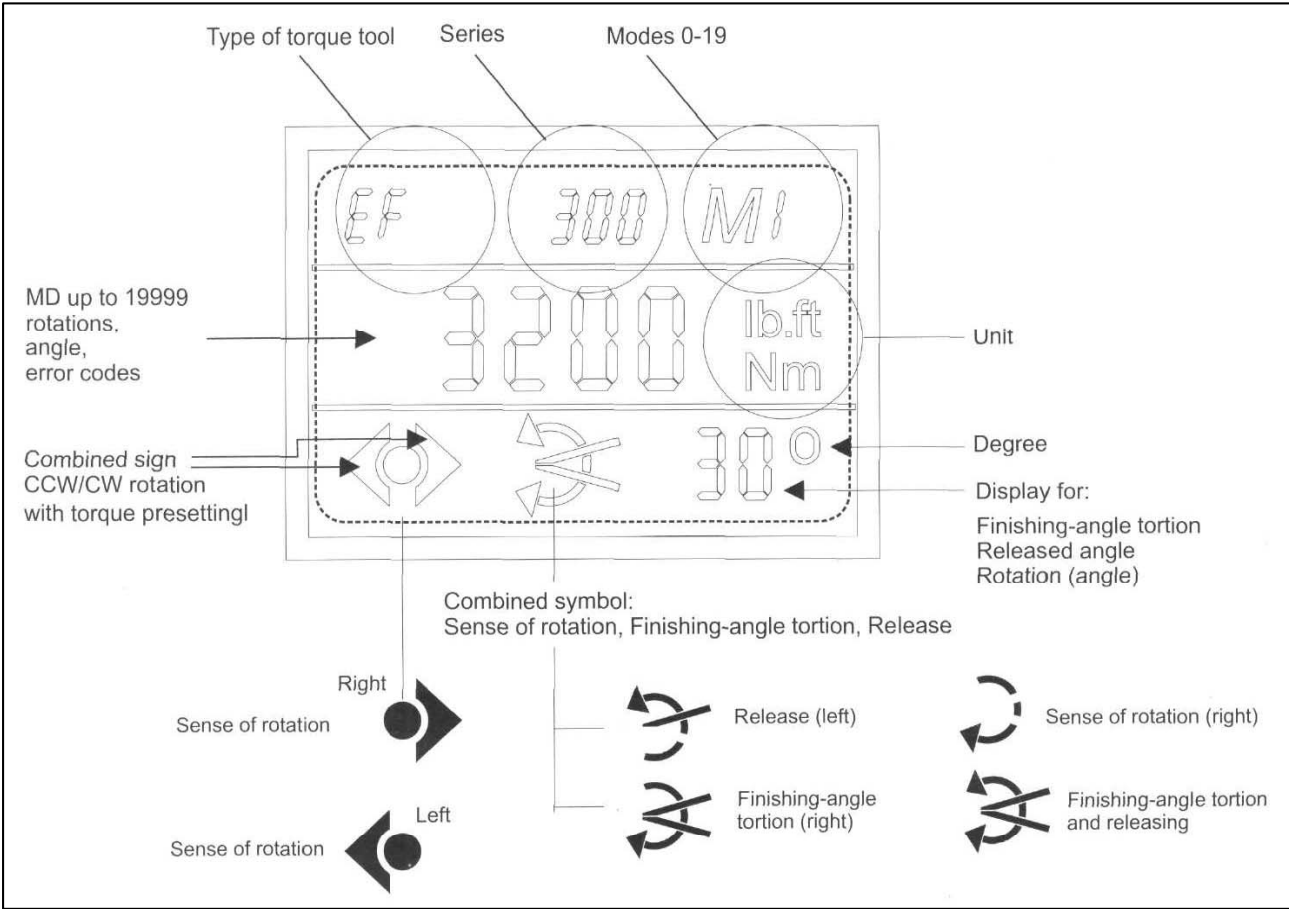

## 4. Mechanical Operation

### 4.1 Tightening and Loosening (Titan **ETite™** -EF, EFW, ETC, ETC/L and "plus" Versions)

#### **WARNING!**



Be aware of rotating support arms or impact sockets. Keep clothing, hair or any loose objects clear of moving parts. Always wear proper protective clothing such as glasses, ear protection and gloves during tool operation.

Do not leave the **Torque Wrench** unattended while in operation. A safe distance of operation is approx. one arms length from the tool while in operation. Never place hand on support arm (DMA) while in operation. Serious bodily injury can occur!

Always place standard nut/-connector completely on screw/nut. Faulty screw connections may lead to materials overload. Moving parts may cause bruises or serious bodily injury.

#### **CAUTION!**



Keep the **Torque Wrench** in a vertical position (6) to the wrench axis while bolting in order to avoid damage to socket and/or the application due to side loading (5).

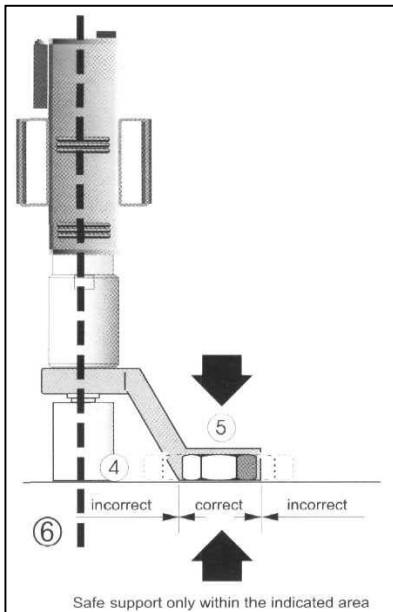

#### **Tightening and loosening screw connection procedures are as follows:**

- place the **Titan ETite™ - Torque Wrench** with Standard nut/-connector completely on screw/nut
- support arm of the **Titan ETite™ EF-Torque Wrench** must be placed on the same level as standard nut/-connector (4). Make sure a safe and stable counter mounting (5) is provided.
  - keep the **Titan ETite™ - Torque Wrench** in a vertical position while bolting
- the motor will stop upon reaching the preset torque
  - a) Counter Force = Motor Force!
  - b) Torque Reaction = Motor Torque
  - c) the pre-set torque has been reached
  - torque direction can now be changed - switch on tool shortly until support arm is free - switch off motor. (This procedure is not necessary with the "AUTOMATIC - Function" of the **Titan ETite™ -EFp/i/s / ETCp/us**)
  - Remove tool, place it on next screw/nut - repeat bolting procedure.

4.2 Tightening and Loosening Titan ETite™ -EFR and Titan ETite®-EF-SG

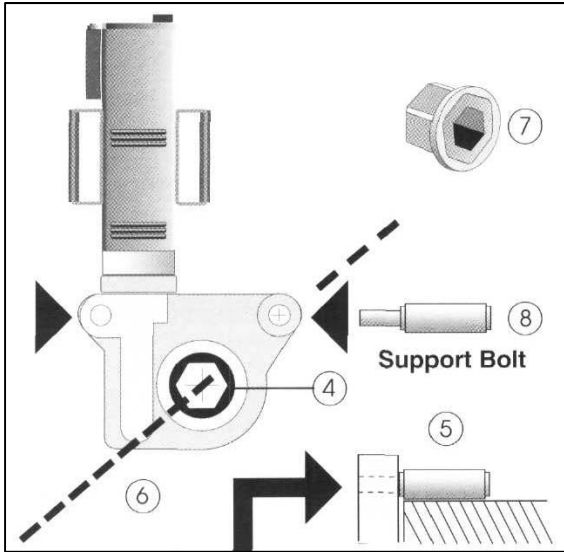

Safe support is only achieved when the Support Bolt is completely inserted into the shells of the casing.

Titan ETite®-EFR (Drawing left side)

**CAUTION!**



Insert the support bolt (8) completely in the housing bolts of the Titan ETite™ - EFR- Torque Wrench in order to avoid damage.

For tightening and loosening screw connections follow the same instructions as stated with the Titan ETite™ @ - EF Torque Tools. On the radial drive of the Titan ETite™ - EFR the torque wrench can be operated in a 90-degree angle due to the drive direction (6). The drive is carried out by a fixed socket size (4). The Titan ETite™ - STA is used to reduce the socket size (7). Torque support is done by a support bolt (8). Make sure to have a safe and stable support (5). (Also see Drawing below.)

Application Titan ETite™ EFR

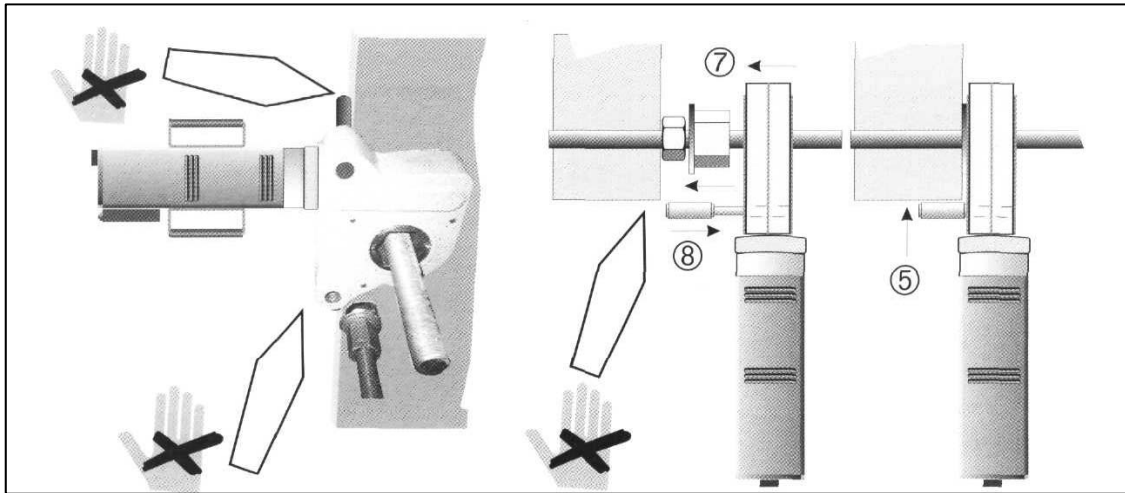

**WARNING!**



Never place hand between the heat plate exchanger and the support bolt. Always carry the tool by the grip. There is a high risk of bruise and injury.

Titan **ETite™** ®- EF-SG

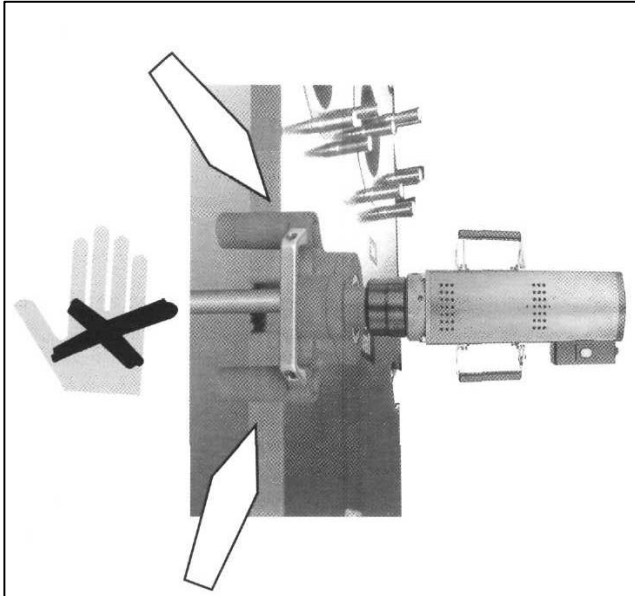

**WARNING!**



**Never** place hand between the heat plate exchanger and the support (support arm). Always carry the tools by the grip. There is a high risk of bruise and injury.

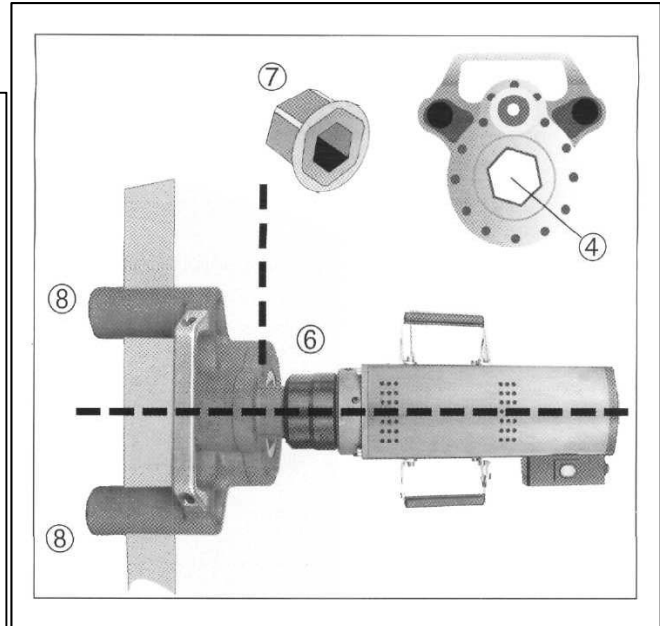

For tightening and loosening screw connections follow the same instructions as stated with the **Titan ETite™ - Torque Tools**.

Place the **Titan ETite™ - EF-SG** completely on nut and operate the tool perpendicular to screw axis (6). The drive is carried out by a fixed socket size (4). The **Titan ETite™ - STA** is used to reduce the socket size (7). Torque support is done by a support bolt (8). Make sure to have a safe and stable support (5). (Also see Drawing below.)

Application Titan **ETite™** ® - EF-SG

**Titan ETite®-STA**

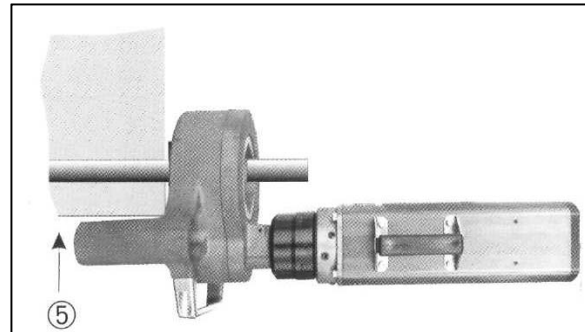
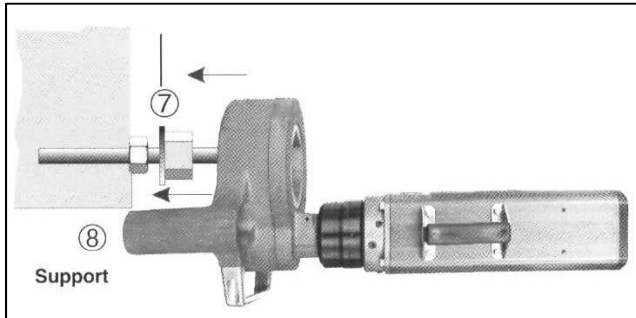

4.3 Finishing or Interrupting Operation (also with Replacements)

When not in use, before maintenance and when replacing tools **always** disconnect the **Titan ETite™ - EF-Torque Wrench** from power supply.

**WARNING!**

**Never** carry the tool by the power cord. Always disconnect the cord by pulling at the plug. Protect cord from heat, oil and sharp edges to avoid accidental shock.

## 5. Noise and Vibration

Sound pressure level: measured in accordance with German Machinery-Noise-Information-Leaflet - 3.GSGV dated 18. January 1991, §1 .paragraph 1 e, at maximum equipment performance is just over 85 dB(A). Please use ear protection in this case!

In accordance with §1, paragraph 2 of the same leaflet, sound pressure levels were measured for different working cycles, with the sensor positioned at a distance of 1 m to the geometric centre of the machine. Vibrations become moderate just prior reaching the pre-set torque.

## 6. Working Test

### 6.1 Visual- and Mechanical Check

Check grounded cords and plugs, operational- and elements of display, housing and accessories, i.e. Support Arm (DMA) etc. regularly. Faulty parts must be replaced by authorized personnel only or return the tool in original packaging to your nearest **Titan ETite™** - Partner or manufacturer.

Particles of dirt within the hydraulic system may result in disturbances, faulty functions and break down of motor.

### 6.2 Meeting The Deadline

The following operational- and service requirements must strictly be adhered to.

## 7. Maintenance/Serviceing

### 7.1 Replacement of Impact Socket and Support Arm

#### CAUTION!



Never use a tool that has been damaged.

Use original **Titan ETite™** - parts only.

**Use only High Quality IMPACT Sockets. Never are standard sockets to be used with this product.**

- Disconnect power cord from power source
- Place the **Titan ETite™ -Torque Wrench** on a flat surface
- Remove rubber ring and safety pin/bolt - standard nut
- Remove DMA, loosen securing if necessary
- Reverse operation for replacement

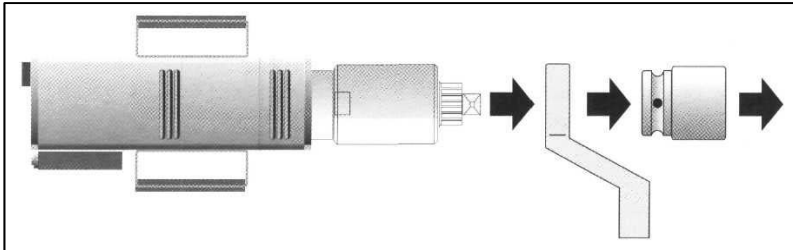

**Titan ETite™ DMA**  
Support Arm.  
Torque Sensor

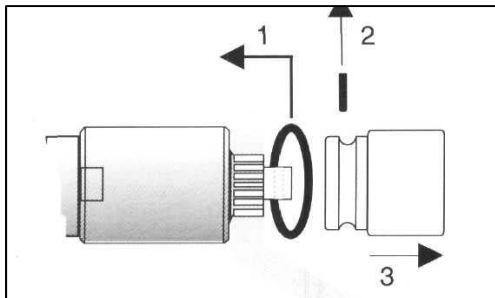

**Titan ETite™ STACO**  
Standard Nut

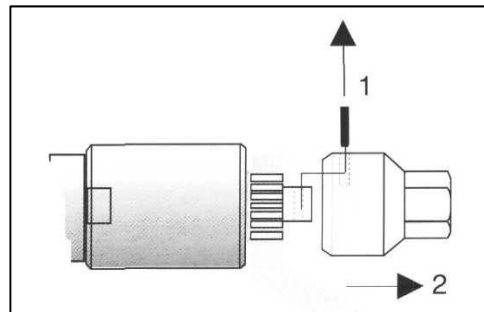

**Titan ETite™ -STABI**  
Standard Connector

## Replacement of the **Titan ETite™ -STA** (Standard Adapter) and the Support Bolt Type EFR

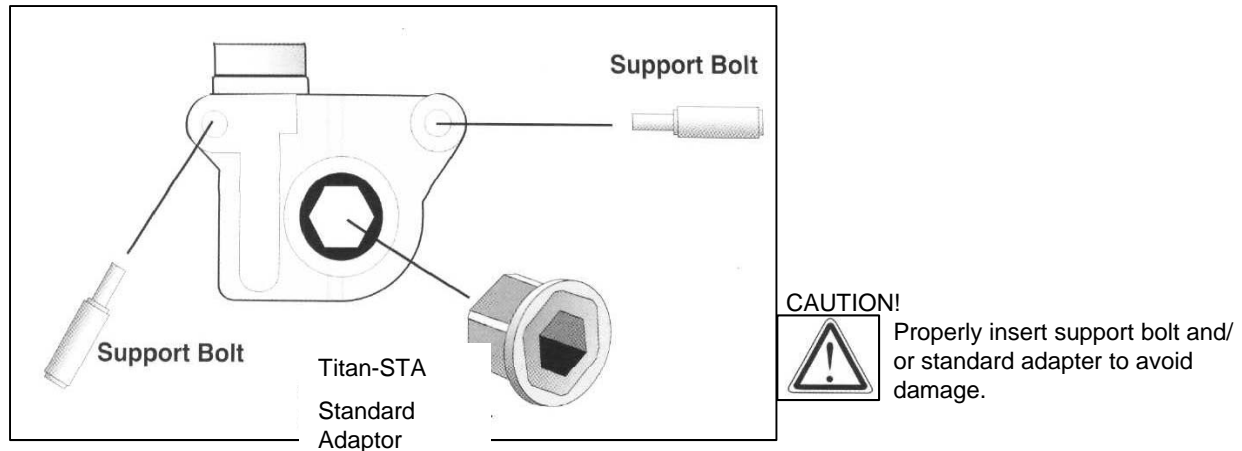

### 7.2 Maintenance Periods

#### NOTE!



To guarantee long life and proper power output of your **Titan ETite™ -Torque Wrench** have the tool inspected and maintained regularly (Power-Check, Motor-Check, Safety-Check).

#### Maintenance Periods:

Have the tool inspected **once a year** or after a **maximum of 1.000 operational hours**.

Always send the tool in the original packaging to your nearest **Titan ETite™ -Partner** or manufacturer.

### 7.3 Operational Points

#### Note!



The tool break in period is 25 hours of use. Afterward we recommend recalibration of the tool. Thereafter the recommended periodicity of calibration is 1 year.

#### IMPORTANT!



Please note that accuracy of the tool is +/- 5% when used at the normal operating periods, corresponding voltage (100-253 V / 45-66 Hz) and nominal sensitivity (2 kW).

In case of degrading performance or other apparent damage immediately send the **Titan ETite™ Torque Wrench** back to your **Titan ETite™ - Partner** or manufacturer in original packaging.

## 8. Technical Points

#### IMPORTANT!



For safety reasons and in order to avoid a **rise in temperature** an automatic switch off of temperature is integrated in all types of the **Titan ETite™ - EF / ETC / ETC/L-Torque Wrenches**. In case the tool has turned off due to high temperature (**all light-emitting diodes on operation desk are flashing**), **do not** switch off **power supply** otherwise the **cooling ventilation** is out of operation! The tool is ready for use again after a short period of cooling (LEDs have stopped flashing).

### 9. Storing the Tool when not in use

When **not in use** keep your **Titan ETite™ - Torque Wrench** in a dry, secure place out of unauthorized personnel. Swiveling parts need to be protected against oxidation.

## 10. Appendix

- Technical Details (Flow Chart)
- **Technical Order** (Replacement of Power Supply Plug) - **Page 23**
- Accessories: e. g.: Standard Adapter STA, Standard Connector STABI, Torque Sensor DMA, Standard Nut STACO etc.
- Explanations of Conformity, EU-Standards, CE etc.

Replacing the power supply plug of the  
Titan **ETite™** -torque tools

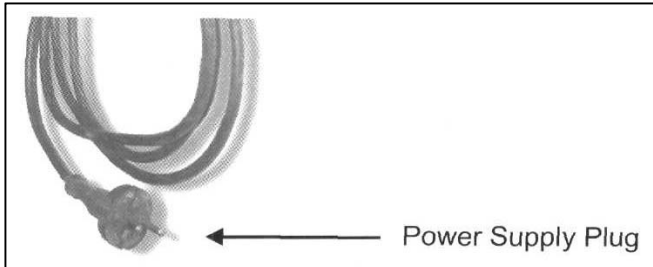

**ATTENTION**

Replacement of plug must only be performed by authorized, factory trained personnel



**Proceed as follows:**

1. Disconnect tool from power supply
2. Cut off plug from cable

**ATTENTION - Important Information**

All Titan **ETite™** torque tools are equipped with a 3-wire grounded cord

If you change the plug it should be changed by a certified and qualified electrician

The Titan **ETite™** EF Torque Tools are equipped with a metallic housing which has to be grounded. **Do not circumvent this safety feature.**

All plugs must be grounded plugs

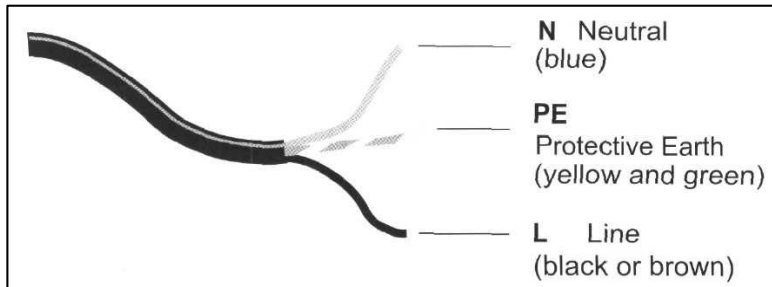

**ATTENTION**

After connecting the plug please check electrical safety of the tool.

Incorrect connection may lead to deadly injuries due to electric shock.

## Notes



**WARNING!**

Indicates a possibly dangerous situation.  
If not avoided injuries or danger for life can be the consequences.



**CAUTION!**

Indicates a possibly dangerous situation.  
If not avoided, minor or serious injuries can be the consequences.  
This signal also indicates warning for damage to the tool.



**IMPORTANT or NOTE!**

Indicates Points for operation and especially useful pieces of information.  
Neither a dangerous nor harmful situation exists.



**WARNING!**

Depending on the working environment and how the  
**Titan ETite™ - Torque Wrench** is used, local health and  
safety regulations may require you to wear protective gear (e.g.  
safety shoes, protective helmet, etc.)

**Titan Technologies International, Inc.**

**9001 Jameel Road, Suite 180**

**Houston, TX. 77040 USA**

**Tel: +1-281-449-9994 Fax: +1-281-449-9996**

[www.TitanTi.com](http://www.TitanTi.com)



**TITAN**  
TECHNOLOGIES INTERNATIONAL, INC.

SUPERIOR BOLTING SOLUTIONS

Titan Technologies reserves the right  
to change specifications without prior notice

GBA/ EF\_ETC\_ETC/L\_plus/2/270405/LE