

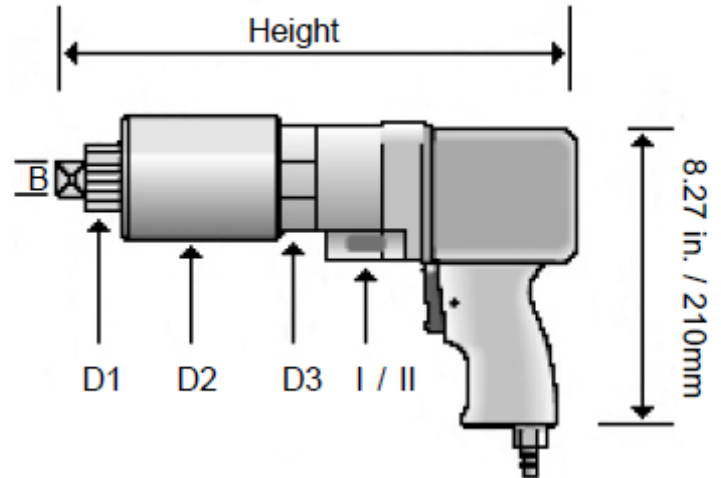

SUPERIOR BOLTING SOLUTIONS®

AT25000 F2

AirTite Pneumatic Torque Wrenches



AT25000 F2 AirTite F Series Two Speed:

Torque Range 1st Gear:	8482 – 25,077 ft lb 11,500 – 34,000 nm	Height:	22.44 In 570 mm
Torque Range 2nd Gear:	2434 – 7154 ft lb 4700 – 13,900 nm	Free Speed (rpm):	1st gear 0.4 2nd gear 0.8
Square Drive (B):	2 1/2 In	Weight: (without support)	132.27 lb 60 kg
D1:	SW 120	5% Accurate Pressure Group:	15 ft. hose assy.
D2:	10.93 In 275 mm	Filter/Regulator/Lubricator Assy:	Operaton/ Maintenance Manual
D3:	10.83 In 275 mm	Pressure to Torque Chart:	Supplied with Calibration Certificate
Mechanical selection switch- for power/run-down gear (AT-F2 gear):	QUIET - 66-78 dB(A)	Precise and Accurate +/-5%:	360 Degree Articulating Motor

(AirTite Seies Accessories Professional Pictures)

SUPERIOR BOLTING SOLUTIONS®

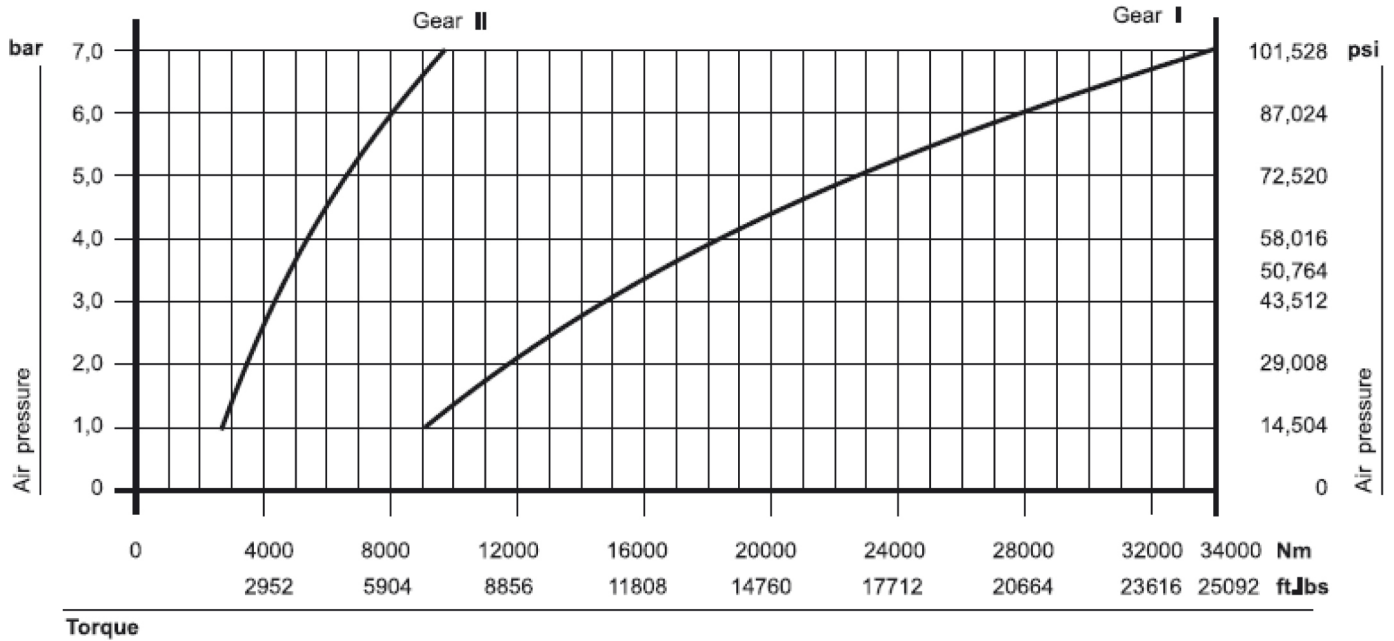

All curves are approximate values.
Unstable compressed air values can cause derivations.

Torque

Gear II	Nm	Ft Lbs
Bar	Max	Max
2	3310	2420
3	4185	3086
4	5290	3903
5	6480	4781
6	7940	5855
7	9122	7171

Gear I	Nm	Ft Lbs
Bar	Max	Max
2	11,575	8539
3	14,645	10,801
4	18,520	13,662
5	22,520	16,732
6	27,785	20,493
7	34,025	25,098

Operating pressure on the machine
Air consumption: 21 – 32 cfm.