

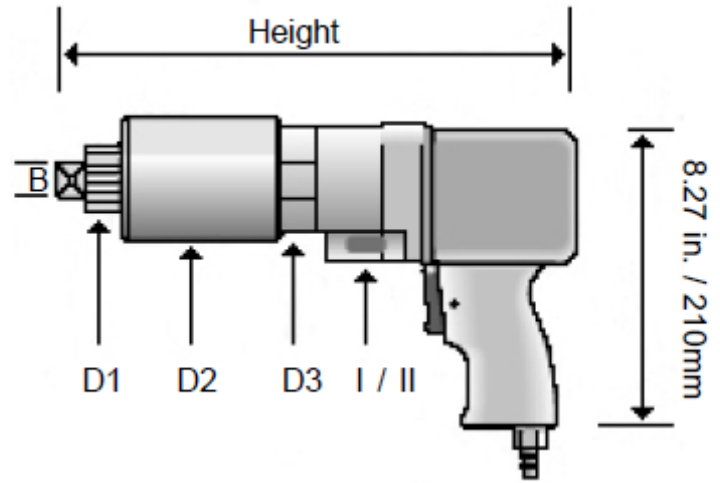

SUPERIOR BOLTING SOLUTIONS®

# AT2650 F2

AirTite Pneumatic Torque Wrenches



AirTite F2-Series Two Speed

Torque Range 1st Gear:	904 – 2652 ft lb 1225 – 3595 nm	Height:	14.17 In 360 mm
Torque Range 2nd Gear:	284 – 834 ft lb 385 – 1130 nm	Free Speed (rpm):	1st gear 5 2nd gear 15
Square Drive (B):	1 In	Weight: (without support)	19.84 lb 9 kg
D1:	2.13 In 54 mm	5% Accurate Pressure Group:	15 ft. hose assy.
D2:	3.35 In 85 mm	Filter/Regulator/ Lubricator Assy:	Operaton/ Maintenance Manual
D3:	3.46 In 88 mm	Pressure to Torque Chart:	Supplied with Calibration Certificate
Mechanical selection switch- for power/run-down gear (AT-F2 gear):	QUIET - 66-78 dB(A)	Precise and Accurate +/-5%:	360 Degree Articulating Motor

(AirTite Seies Accessories Professional Pictures)

## Accessories

ARA 16 54 DW	Deep Reaction Arm
ARA 16 54 CN	Crab Nut Reaction Arm
ARA 16 54 ML	Mill Liner/Extended Reaction Arm
SRA 16 54	Straight Reaction Arm
PSR 16 54	Splined Reaction Ring
SDE 16 54 13	Sq. Dr. Extension 13"
SR 54	Safety Ring

**SUPERIOR BOLTING SOLUTIONS®**

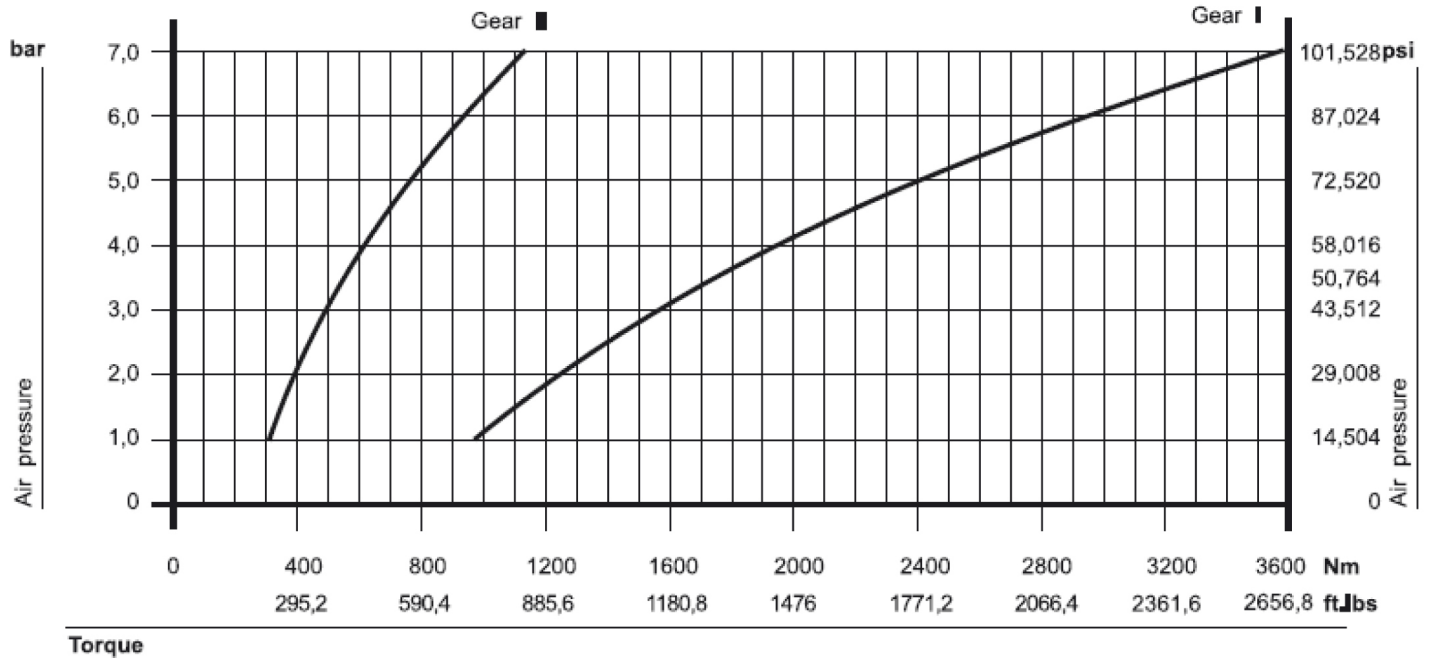

All curves are approximate values.  
Unstable compressed air values can cause derivations.

Torque

Gear II	Nm	Ft Lbs
Bar	Max	Max
2	385	283
3	485	358
4	615	453
5	750	555
6	920	680
7	1130	833

Gear I	Nm	Ft Lbs
Bar	Max	Max
2	1225	902
3	1545	1141
4	1955	1443
5	2395	1768
6	2935	1768
7	3595	2652

Operating pressure on the machine  
Air consumption: 21 – 32 cfm.