

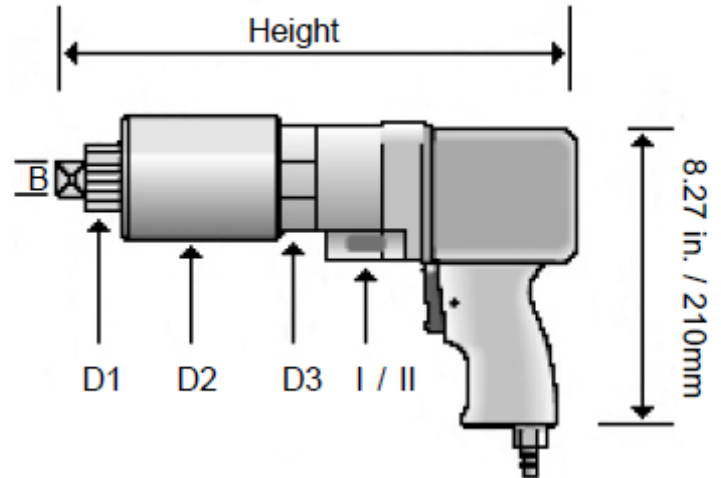

SUPERIOR BOLTING SOLUTIONS®

AT35000 F2

AirTite Pneumatic Torque Wrenches



AT35000 F2 AirTite F Series Two Speed:

Torque Range 1st Gear:	11,801 – 35,845 ft lb 16,000 – 486,000 nm	Height:	22.44 In 570 mm
Torque Range 2nd Gear:	3467 – 10,252 ft lb 4700 – 13,900 nm	Free Speed (rpm):	1st gear 0.3 2nd gear 0.6
Square Drive (B):	2 1/2 In	Weight: (without support)	132.27 lb 60 kg
D1:	SW 120	5% Accurate Pressure Group:	15 ft. hose assy.
D2:	10.83 In 275 mm	Filter/Regulator/Lubricator Assy:	Operaton/ Maintenance Manual
D3:	10.83 In 275 mm	Pressure to Torque Chart:	Supplied with Calibration Certificate
Mechanical selection switch- for power/run-down gear (AT-F2 gear):	QUIET - 66-78 dB(A)	Precise and Accurate +/-5%:	360 Degree Articulating Motor

(AirTite Seies Accessories Professional Pictures)

SUPERIOR BOLTING SOLUTIONS®

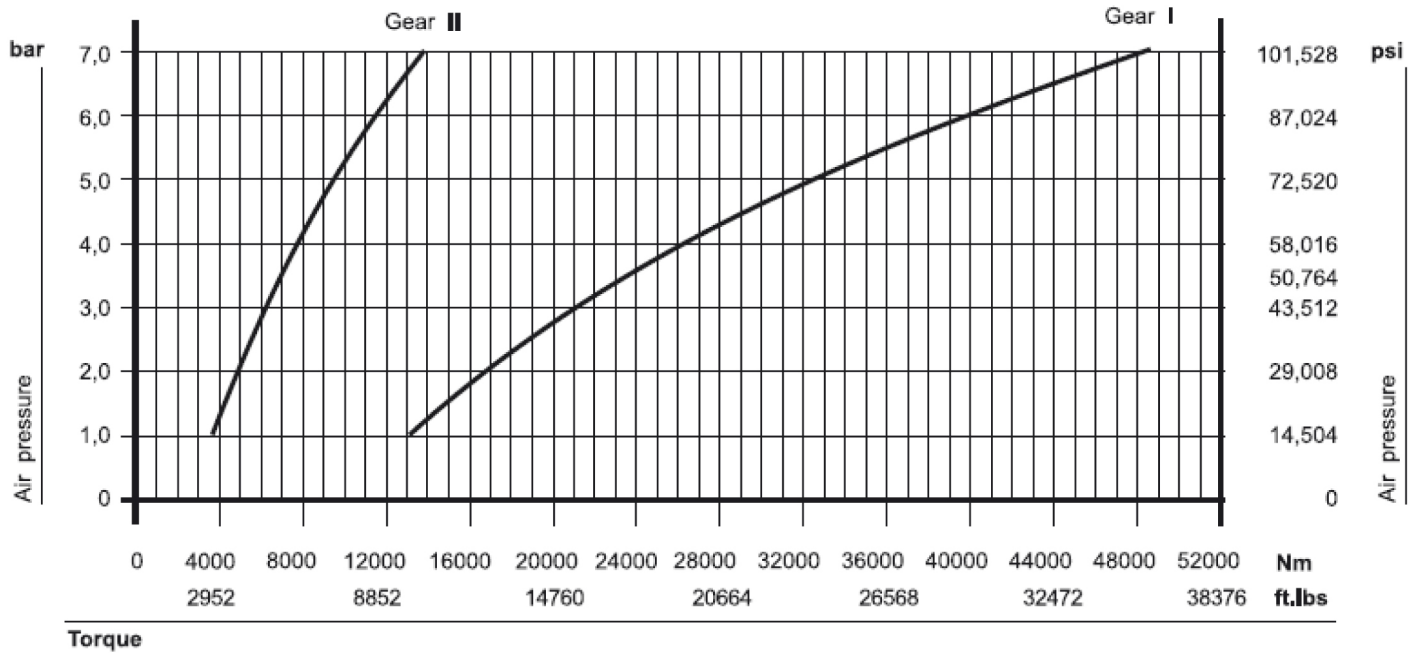

All curves are approximate values.
Unstable compressed air values can cause derivations.

Torque

Gear II	Nm	Ft Lbs
Bar	Max	Max
2	4725	3485
3	5975	4408
4	7560	5576
5	9260	6829
6	11,340	8364
7	13,890	10,244

Gear I	Nm	Ft Lbs
Bar	Max	Max
2	16,540	12,198
3	20,920	15,429
4	26,460	19,517
5	32,405	23,903
6	36,690	29,275
7	48,610	35,855

Operating pressure on the machine
Air consumption: 21 – 32 cfm.