

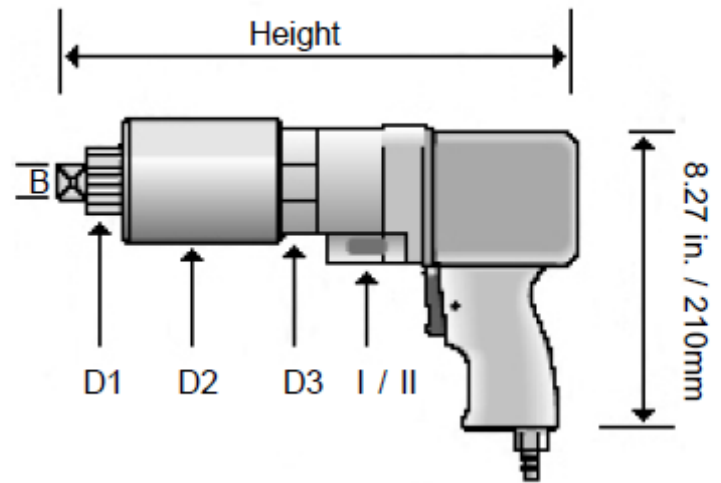

SUPERIOR BOLTING SOLUTIONS®

AT8100 F2

AirTite Pneumatic Torque Wrenches



AT8100 F2 AirTite F Series Two Speed:

Torque Range 1st Gear:	2762 – 8121 ft lb 3745 – 11,010 nm	Height:	16.93 In 430 mm
Torque Range 2nd Gear:	867 – 2548 ft lb 1175 – 3455 nm	Free Speed (rpm):	1st gear 1 2nd gear 4
Square Drive (B):	1 1/2 In	Weight: (without support)	52.91 lb 24 kg
D1:	3.58 In 91 mm	5% Accurate Pressure Group:	15 ft. hose assy.
D2:	6.81 In 172 mm	Filter/Regulator/ Lubricator Assy:	Operaton/ Maintenance Manual
D3:	6.81 In 173 mm	Pressure to Torque Chart:	Supplied with Calibration Certificate
Mechanical selection switch- for power/run-down gear (AT-F2 gear):	QUIET - 66-78 dB(A)	Precise and Accurate +/-5%:	360 Degree Articulating Motor

(AirTite Seies Accessories Professional Pictures)

Accessories

ARA 24 91 DW	Deep Reaction Arm
ARA 24 91 CN	Crab Nut Reaction Arm
ARA 24 91 ML	Mill Liner/Extended Reaction Arm
SRA 24 91	Straight Reaction Arm
PSR 24 91	Splined Reaction Ring
SR 91	Sq. Dr. Extension 13"
ARA 24 91 DW	Safety Ring

SUPERIOR BOLTING SOLUTIONS®

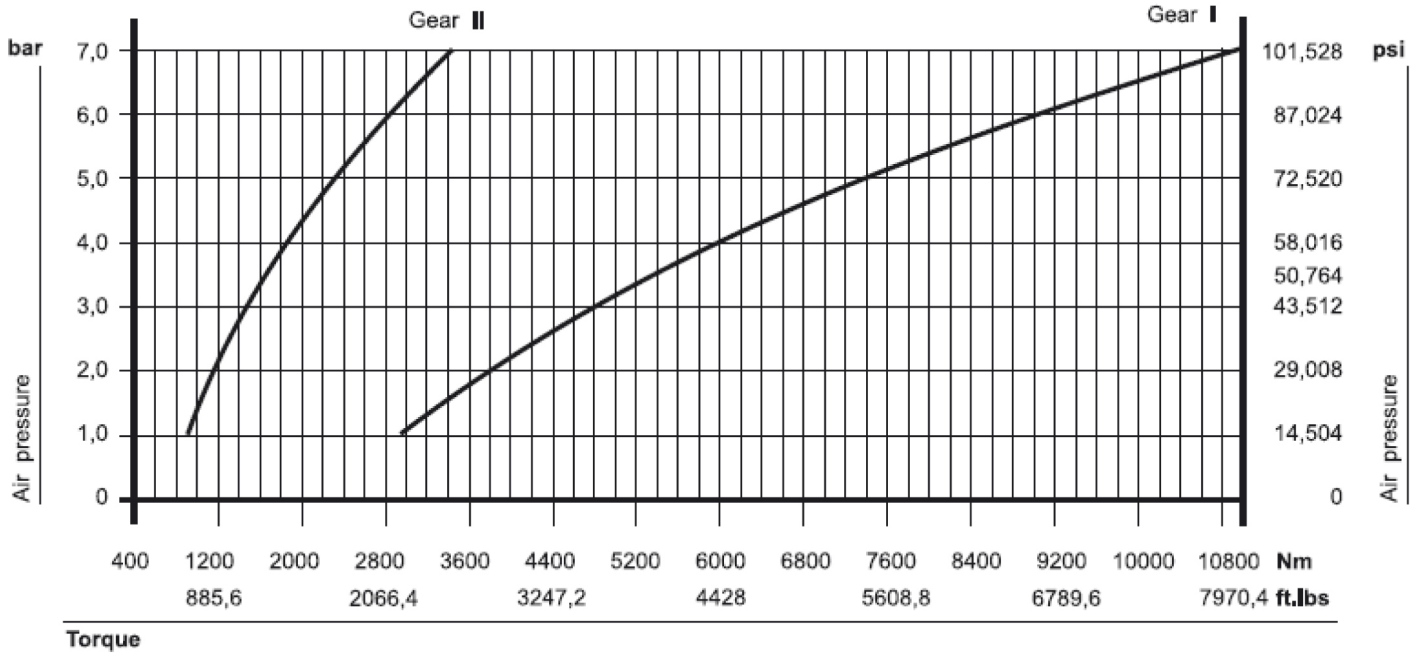

All curves are approximate values.
Unstable compressed air values can cause derivations.

Torque

Gear II	Nm	Ft Lbs
Bar	Max	Max
2	1175	867
3	1490	1097
4	1880	1368
5	2305	1700
6	2820	2082
7	3455	2550

Gear I	Nm	Ft Lbs
Bar	Max	Max
2	3745	2763
3	4740	3495
4	5995	4240
5	7340	5514
6	8990	6631
7	11,010	8121

Operating pressure on the machine
Air consumption: 21 – 32 cfm.