



SUPERIOR TECHNOLOGIES • SUPERIOR SOLUTIONS™

TITAN EXPRESS EXE-MAX-FF1

Serial N°:

Voltage:

Date:

Gauge: N°



Titan Technologies International, Inc.
9001 Jameel Rd. Ste. 180, Houston, TX 77040 USA
Tel: (281) 449-9994 Fax: (281) 449-9996
Email: sales@TitanTi.com
Web: www.TitanTi.com



TECHNICAL DATA

TITAN EXPRESS HE-055-3-xxxV-FF-1Port

MOTOR : .56 Kw / .75HP

PUMP :

Type 3 stages
Flow 6.4 l/min from 0 to 1000 psi
1.8 l/min from 1000 to 3000 psi
0.7 l/min from 3000 to 10,000 psi

Max. Pressure 10,000 psi

SIZE :

Length 41 cm / 16.2 in
Width 30 cm / 11.8 in
Height 44 cm / 17.5 in

Weight : 27 kg / 59 lbs

OIL TANK : 1.750 Gallon

OIL : Use only Grade 46 mineral hydraulic oil. Proper hydraulic oil is available from Titan Technologies.
ISO 6743-4 HV NFE 48602 HV



WARNING!!!

- ❶ Before operating the pump, make sure all hose connections are tight – use the proper tools to tighten connections.
- ❷ Do not overtighten the connections. Connections need only to be tightened securely and leak-free. Overtightening may cause premature thread failure or high pressure fittings to split at pressures lower than their rated capacities.
- ❸ Hydraulic line disconnection: fully retract the cylinder and remove any load by releasing the white button on the remote control.
- ❹ Should a hydraulic hose ever burst or rupture, immediately shut off the pump. **Never attempt to grasp a leaking hose under pressure with your hands. The force of the escaping hydraulic fluid could cause serious and permanent injury. Check hoses for kinks. Replace kinked hoses .**
- ❺ Avoid any condition or conditions which could damage the hose and impair the pump or valve's performance. Never allow the hose to kink, twist, curl or bend so tightly that the oil flow within the hose is blocked or reduce. This could damage the hose and possibly result in serious injury to persons working in the immediate vicinity.
- ❻ Do not subject the hose to any potential hazard (ex: fire, extreme heat or cold, heavy impact or sharp surfaces) which might rupture or weaken the hose.
- ❼ Periodically inspect the hose for signs of wear. **Never use a defective hose with any pressurized equipment.**
- ❽ Never paint the hose or the couplers!
- ❾ Hose material and coupler seals must be compatible with the hydraulic fluid used.
- ❿ The pump maximum working pressure is 10,000 PSI / 700 bar. Your Titan Technologies Hydraulic Wrenches are also rated at 10,000 PSI as are hydraulic fittings & hoses supplied by Titan.
If using alien equipment, please make sure that all hydraulic equipment such as wrenches, hoses, etc. used with this pump are rated at 10,000 PSI operating pressure.
- ⓫ **Check for proper electrical supply before connecting.**
- ⓬ This motor may spark. Do not operate in an explosive atmosphere or in the presence of conductive liquids. If you intend to use your Titan Equipment in an explosive environment, USE ONLY Air/Hydraulic explosion Proof Models. **Never use an electric power pump in explosive environments.**
- ⓭ Compare motor nameplate against power availability to prevent motor burnout or dangerous electrical overloading.



PREVENTIVE MAINTENANCE – EXPRESS Series Pumps

⚠ WARNING : THE ELECTRICAL POWER CORD MUST BE DISCONNECTED FROM ELECTRICAL OUTLETS BEFORE PERFORMING MAINTENANCE OR REPAIR PROCEDURES.

EXPRESS pumps are precision-built hydraulic units and, as such, do require a certain amount of care and maintenance.

1. **Hydraulic Oil :** oil should be completely changed after every 40 hours of operation, or at least twice a year. Always make sure the reservoir is filled with fluid. If additional oil is required, use only high-grade hydraulic, such as Titan grade 46.
2. **Quick-Disconnects :** Fittings should be checked periodically for leaks. Dirt and foreign materials should be kept away from fittings. Clean before use.
3. **Gauge :** TITAN gauges are liquid filled. Should this liquid level drop, it indicates external leakage, and replacement is necessary. Should the gauge fill with hydraulic oil, it indicates internal failure and should be discarded.
4. **Motor :** The motor shaft and bearings should be flushed and lubricated once a year.
5. **Filter :** The filter should be replaced twice a year for a normal use, and more often if pump is in daily use.
6. **Remote control :** The electric cord or air line to the remote control should be checked for kinks or obstructions periodically. If there is a bend or break in the line, it must be replaced. The spring-loaded buttons on the remote handle should be checked in the event of operating difficulties.
7. **Oil tank :** Should be checked for prevention of leakage.
8. **Pumping unit :** The pump should be overhauled every 2 years. This can be done by TITAN or by a qualified hydraulic service center.

To have a longer life pump, it is better to clean up the pump after use.



OPERATION MANUAL

1. Prior to using the pump :

- 1.1 Check oil level in reservoir.
- 1.2 Check the pump, remote control and hydraulic hose for signs of damage.
- 1.3 Connect the remote control unit.
- 1.4 Connect the twin line hoses and check all system fittings and connections to be sure they are tight and leak free.
- 1.5 Ensure that the torque valve is set to zero by fully rotating it anti-clockwise.
- 1.6 Be sure the electrical connection is grounded. Check that your power agrees with the motor nameplate. Plug power cord into outlet.

2. Operation :

- 2.1 Press and release the white button on the remote control to START THE PUMP.
- 2.2 The tool is pressurised by holding the white button down and pressurised by releasing it.
- 2.3 Press the black button to STOP THE PUMP.
- 2.4 The motor will automatically switch off approximately 1 minute after the last operation on the remote control.
- 2.5 Bleed to the pump to ensure that there air is purged from the system, by opening the torque control valve fully anti-clockwise and with motor running hold the white button down for 15-20 seconds release and repeat.

3. Torque Setting :

- Make these adjustments BEFORE putting torque wrench on nut or bolt head.
- 3.1 See torque wrench chart to have the amount of pressure required to produce desired torque.
 - 3.2 Press and hold the white button to advance the piston.
 - 3.3 While holding the button, slowly turn the pressure valve (clockwise) to increase pressure on the gauge.
 - 3.4 Stop when the required pressure appears on the gauge and release the button.
 - 3.5 Repeat the 3.2 to control that the pressure on the gauge is right.
 - 3.6 If the pressure on the gauge is not good, repeat step 3.2 to 3.5.
 - 3.6 Once the desired pressure has been reached tighten the lock nut on the pressure valve.
 - 3.7 You can put the tool on the nut and run the pump.

3A Operation with the optional Automatic Torque System:

- 3A1 Adjust the requested pressure / torque.
Start the motor by pressing and releasing the white button on the remote control.
- 3A2 Press and hold the blue button. The Automatic Torque System will advance and retract the tool piston until the requested pressure / torque is reached.
- 3A3 If the tool doesn't rotate anymore, release the blue button and press the white button to control that the requested pressure / torque is reached.
- 3A4 Press the black button to stop the motor.

4. After use :

Be sure that there is no pressure in the line:

- 4.1 Switch off the pump using the black button on the remote control.
- 4.2 Turn off the electrical supply.
- 4.3 Disconnect the hydraulic hoses.

It's very important to clean up as often as you can the pump unit.

HYDRAULIC SCHEME

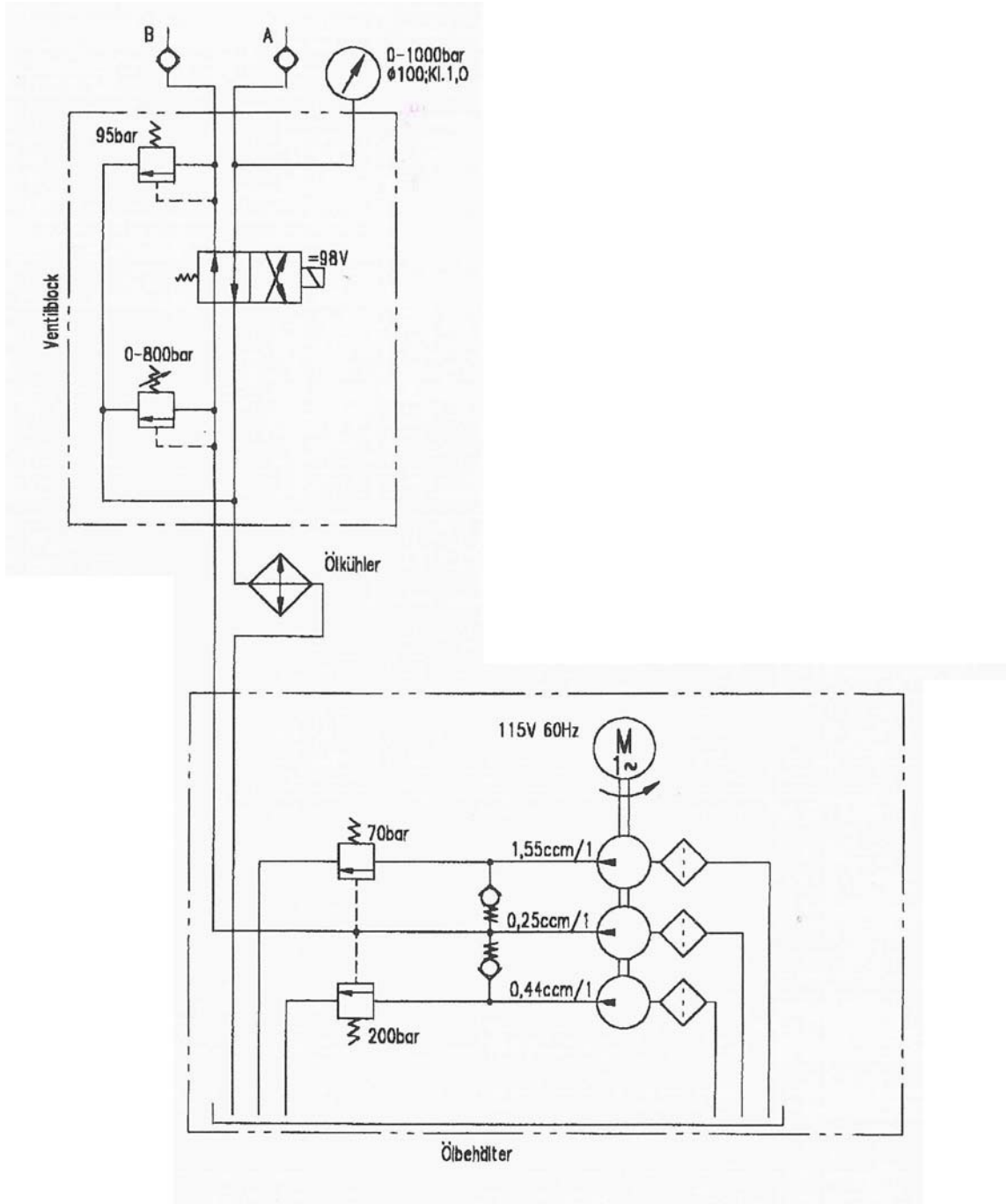

PUMP SCHEME

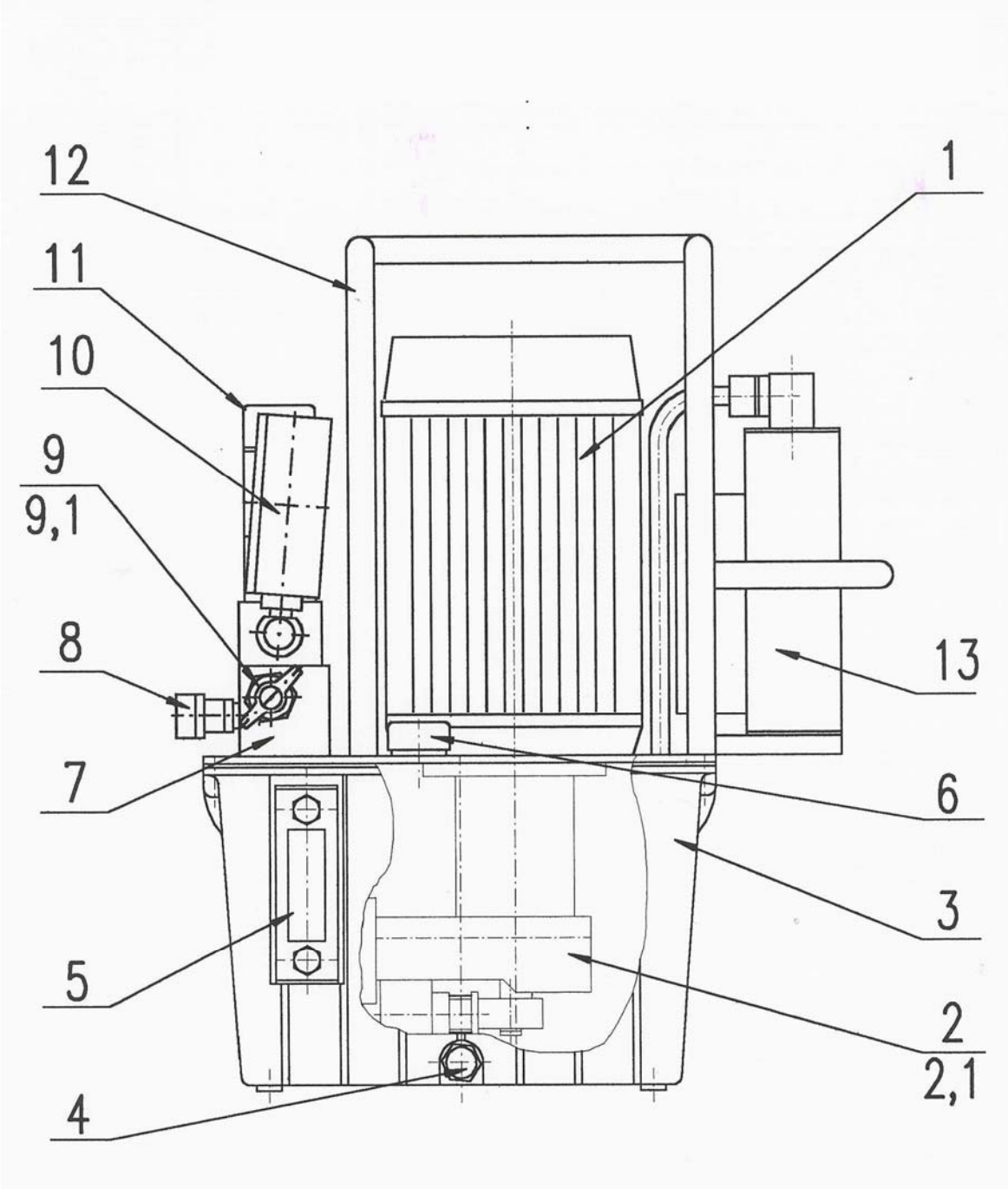

Spare Parts

- 1 Motor + Electric box
- 2 Internal spare
- 2.1 Seals and bearing
- 3 Oil tank
- 4 Hex pipe plug
- 5 Thermometer/Oil level
- 6 Filler plug
- 7 Back pressure valve - Manifold ass.
- 8 Hydraulic couplers.
- 9 Pressure regulator valve.
- 10 Gauge
- 11 Solenoid valve
- 12 Frame.
- 13 Oil cooler
- 14 Remote control



TROUBLE SHOOTING GUIDE

<u>Problem</u>	<u>Probable cause</u>	<u>Solution</u>
Motor runs but no reaction with the tool	1.Quick connect not mated properly. 2.Damaged Connect 3.No or too little oil in reservoir 4.Pressure regulator valve too slow 5.Defective remote control hose	1.Tighten connection until fully secure. 2.Replace. 3.Control and fill up oil level. 4.Increase. 5.replace.
Tool will not retract	1.same as above	1.Same as above
Tool cannot be removed	1.Holding Reaction Pawl is engaged. 2.Cylinder did not retract	1.Pressurize the tool and while keeping the button depressed on the remote control, GENTLY pull back the pawl release lever on the side of the tool. Release the button on the remote & let the piston retract. 2.Check quick connect as described above.
Tool leaks oil	1.Seal damage in cylinder 2.Seal damage in Tru-Swivel	1.Replace seal. 2.Replace seal.
Tool advance in "retract" Mode or "Visa Versa"	1.Quick connects installed in improper sequence.	1.Make sure connects are set up in the right way.
Ratchet returns on retract Stroke.	1.Missing, defective or broken Reaction Pawl	1.Change pawl spring or Reaction Pawl.
Tool will not take successive Strokes	1.Lose or defective quick connect. 2.Operator is depressing advance before oil has a chance to fully return to the reservoir, thus preventing the piston from fully returning before taking the new stroke. 3.Defective Drive Pawl spring 4.Broken Drive Pawl	1.Fully tighten or replace connects on retract side. 2.Wait for oil to return and for the cylinder to retract completely before taking the next stroke. 3.Replace the spring. 4.Replace.
Motor doesn't run	1.no source 2.Pump starved for air 3.Inedequate power supply 4.Defective remote control hose	1.Connect air line. 2.Use minimum 1" dia. Air hose, Need 50 cfm. 100psi 6bar air source. 3.Use proper power source. 4.replace remote control.

Air pump Sluggish	<ol style="list-style-type: none"> 1.Pump starved for air 2.Dirt in air motor 3.Dirty Oil Filter 	<ol style="list-style-type: none"> 1.Use minimum1"dia. Air hose, Need 50 cfm.100psi 6bar air source. 2.Flush motor with solvent, clean, dry and lubricate. 3.Clean or replace.
Air motor frozen	<ol style="list-style-type: none"> 1.FLR missing or broken 2.Rotor bearings frozen 3. Obstruction in air valve 4.Improperly installed remote control hoses 5.defective remote control hoses 6.Defective remote button 	<ol style="list-style-type: none"> 1.replace FLR. 2.Inspect & replace. 3.Inspect & clean. 4.Ensure 3-hose system is connected properly.(color coded) 5.Replace. 6.Replace spring.
Pump will not build pressure	<ol style="list-style-type: none"> 1.Inadequate power supply 2.Pump starved for air 3.Defective pressure regulator valve 4.Defective gauge 5.Dirty oil 6.Clogged FRL 	<ol style="list-style-type: none"> 1.Use proper power source. 2.Use minimum1"dia. Air hose, Need 50 cfm.100psi 6bar air source. 3.Replace. 4.Replace. 5.Clean reservoir and replace oil. 6.Replace FLR.
Drop oiler doesn't work	<ol style="list-style-type: none"> 1.No or too little oil in reservoir 2.Drop oiler misplaced 	<ol style="list-style-type: none"> 1.Control and fill up oil level. 2.Adjust to 5-6 drops/min
No pressure reading on gauge	<ol style="list-style-type: none"> 1.Defective gauge 2.Loose connect 3.defective seals 4.Defective motor coupling. 	<ol style="list-style-type: none"> 1.Replace gauge. 2.Tighten connect. 3.Inspect all seals and replace any defective one. 4.replace motor coupling.